



Internal spray bars

KAM® SR03, SR05, SR10

KAM® SR™ SAMPLE RECEIVERS PER API 8.2, 8.3; ISO 3171 AND ASTM D5854

Made from a light stainless steel, KAM® SR™ Sample Receivers are both extremely portable and rugged. They're designed to collect almost any liquid including crude oil, refined products, chemicals, water and wastewater. They're also designed for convenience with a quick, full-opening top that makes them **easy to clean and inspect** and spray bars that optimize mixing. KAM® SR™ Sample Receivers also include a custom lip seal that prevents any possible contamination, as well as a pressure relief valve and a pressure gauge to ensure the absolute accuracy of your sample.

FEATURES

- User friendly • Easy to clean
- Light weight • Quick connect/disconnect
- Pressure relief valve • Rubber feet prevent dents
- Internal spray bars for optimum mixing

APPLICATIONS

- Marine loading, unloading, lightering
- Truck loading, unloading • Pipeline
- Production • Refinery • Research
- Power plant fuel oil

Email Sales@Kam.com
Tel +1 713 784 0000
Fax +1 713 784 0001

www.KAM.com

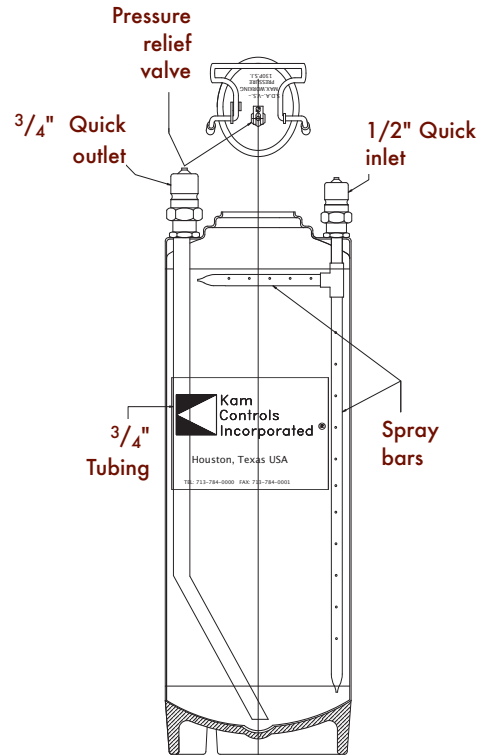
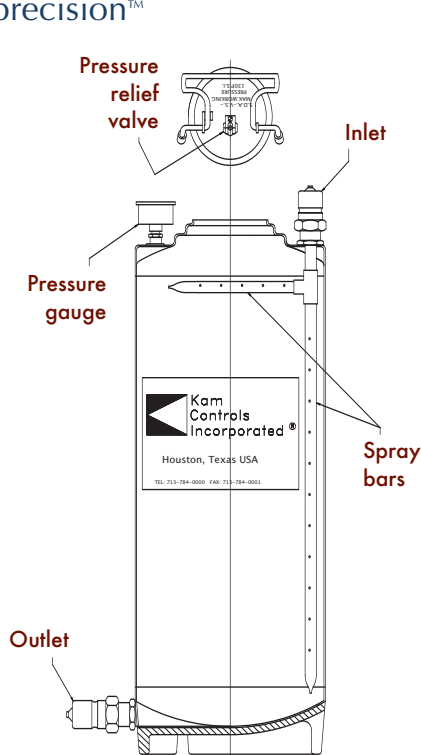

KAM® SR™ SAMPLE RECEIVERS PER API 8.2, 8.3; ISO 3171 AND ASTM D5854

SPECIFICATIONS

- Volume: KAM SR03 - 3 Gallons (11.4 L)
KAM SR05 - 5 Gallons (18.9 L)
KAM SR10 - 10 Gallons (37.8 L)
KAM SR15 - 15 Gallons (56.8 L)
- Pressure: Design - 130 psig
- Material: Stainless steel with viton lip seals
- Inlet: 1/2" Male quick connect
- Outlet: 3/4" Male quick connect
- Dimensions: KAM SR03 - 8.25" diameter x 17.75" high (210mm x 451mm)
KAM SR05 - 8.25" diameter x 25.75" high (210mm x 654mm)
KAM SR10 - 12.25" diameter x 25.75" high (311mm x 654mm)
KAM SR15 - 12" diameter x 41" high (305mm x 1041mm)
- Weight: SR03 - 7 lbs. (3.2kg), SR05 - 9 lbs. (4kg), SR10 - 11 lbs. (5kg), SR15 - 34 lbs. (15.4kg)

Lifetime Service

All KAM® products are backed with lifetime service. Send questions/issues to: AskAnEngineer@KAM.com and we will send an answer or an engineer on site if necessary.

Email Sales@Kam.com
Tel +1 713 784 0000
Fax +1 713 784 0001

www.KAM.com