

## OEM radar transmitter, for aggressive media level measurement



- Compact for level measurement up to 20 m
- 4 ... 20 mA/Hart - 2 wires
- Adjustable with PC
- ATEX approvals  $\text{Ex}$

Type 8136 can be combined with...



**Type 8635**

SideControl Ex



**Type 2035**

Diaphragm valve



**Type 2301 (8692)**

Continuous  
TopControl system

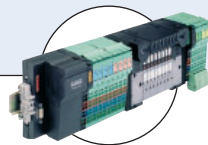

**Type 8644**

Valve islands

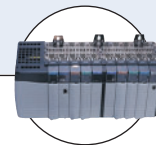

**PLC**

The Type 8136 is a non-contact radar level transmitter for continuous level measurement. The unit is available in two versions:

- with encapsulated horn antenna particularly suitable for level measurement of aggressive liquids in small vessels.
- with plastic horn antenna particularly suitable for flow measurement in open flumes or gauge measurement in waters.

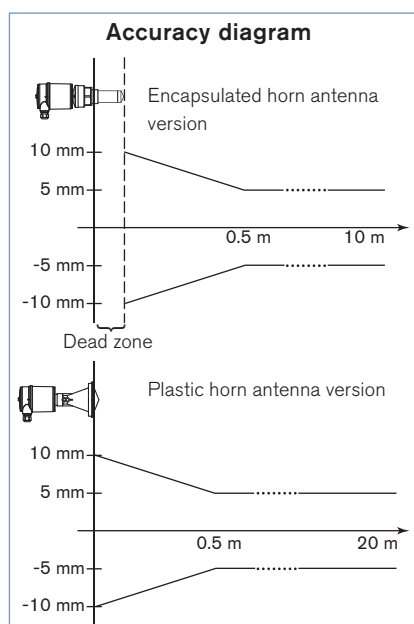

### General data

#### Materials

Housing / Cover	PBT, Stainless steel 316L / PC
Seal ring / Ground terminal	NBR / Stainless steel 316Ti/316L (1.4571/1.4435)
Mounting strap / Fixing screws	Stainless steel 304 (1.4301) / Stainless steel 316L (1.4435)
Wetted parts	
Encapsulated horn antenna version	PVDF / PVDF (completely encapsulated) / FKM
Process fitting / Antenna / Seal	
Plastic horn antenna version	Stainless steel 316L (1.4435)
Process fitting	PBT-GF30 / PP
Horn antenna / Focussing lens	

#### Display \*

LCD in full dot matrix (in option)

#### Process fitting

Thread G 1"1/2 A or NPT 1"1/2 (Encapsulated horn antenna version)  
Mounting strap 170 mm (Plastic horn antenna version)

#### Max. torque mounting boss

4 Nm (mounting screws - strap on the sensor housing)

#### Electrical connection

Cable glands M20 x 1.5

#### Measuring type

Distance between process fitting and product surface

#### Min. dielectric figure

$\epsilon_r > 1.6$

#### Dead zone

50 mm<sup>1)</sup>

#### Measuring range

0.05 up to 10 m (Encapsulated horn antenna version)  
0 up to 20 m (Plastic horn antenna version)

#### Process temperature

-40 up to +80°C (-40 to 176 °F)

#### Vessel pressure

-1 up to 3 bar (-14.51 to 43.53 PSI) (-100 up to 300 kPa)

#### Vibration resistance

Mechanical vibrations with 4.g and 5...100 Hz

#### Temperature coefficient

0.03%/10K (Average temperature coefficient of the zero signal - temperature error)

#### Resolution

max. 1 mm

#### Frequency

K-band (26 GHz technology)

#### Interval

approx. 1 s

#### Beam angle at 3dB

22° (Encapsulated horn antenna vers.); 10° (Plastic horn antenna vers.)

#### Adjustment time

> 1 s (dependent on the parameter adjustment)

#### Accuracy

± 5 mm (see diagram)

\* to be ordered separately

<sup>1)</sup> Encapsulated horn antenna version. In products with low dielectric value up to 50 cm.

Electrical data	
<b>Power supply</b>	14 to 36 V DC or 14 to 30 V DC (Ex ia instrument)
<b>Permissible residual ripple</b>	< 100 Hz: $U_{ss} < 1$ V 100 Hz...10 kHz: $U_{ss} < 10$ mV
<b>Output signal</b>	4...20 mA/HART
<b>Resolution</b>	1.6 $\mu$ A
<b>Fault signal</b>	current output unchanged; 20.5 mA; 22 mA < 3.6 mA (adjustable)
<b>Current limitation</b>	22 mA
<b>Load</b>	see load diagram
<b>Damping (63% of the input variable)</b>	0...999 s, adjustable
<b>Fulfilled NAMUR recommendation</b>	NE 43
Environment	
<b>Ambient temperature</b>	-40 to +80°C (-40 to 176 °F) (operation and storage)
<b>Relative humidity</b>	20-80 %; without condensation
Standards and approvals	
<b>Protection</b>	IP66/IP67 with M20 x 1.5 gland mounted and tightened
<b>Overvoltage category</b>	III
<b>Protection class</b>	II
<b>Standard</b>	
EMC	EN61326
Security	EN61010-1
NAMUR	NE 21; NE 43
<b>Approvals</b>	ATEX <sup>1)</sup> : EN60079-0; EN60079-11; EN60079-26 WHG (overfill protection)
Specifications Ex	
<b>Ⓢ - Protection</b>	Categories 1/2 G or 2G
<b>Ⓢ - Certification</b>	Ex ia IIC T6
<b>Conformity specifications<sup>1)</sup></b>	
Power supply $U_i$	30 V
Short circuit rating $I_i$	131 mA
Power limitation $P_i$	983 mW
Ambient temperature	-40 up to +55°C (-40 to 131 °F) (depend on categories)
Internal capacity $C_i$	negligible
Internal inductivity $L_i$	negligible

1) homologation certificate PTB 08 ATEX 2002X

Load diagram

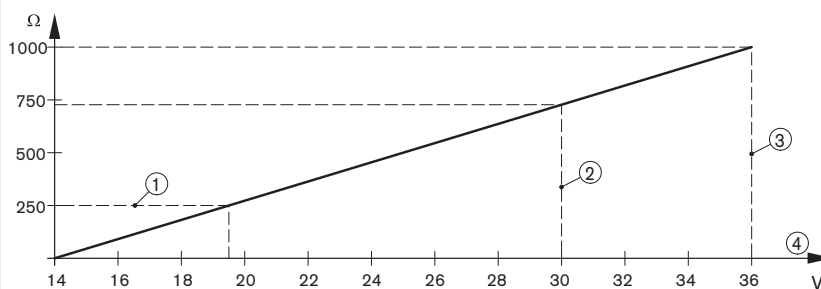

- 1 HART load
- 2 Voltage limit Ex ia instrument
- 3 Voltage limit non-Ex instrument
- 4 Supply voltage

## Target applications

### ■ Dosing and processing systems

Level measurement:

The radar measuring principle is particularly suitable for continuous level measurement of toxic and corrosive substances. The measurement is non-contacting, i.e. there is no direct contact with the medium.

Due to the very small process connection and the PVDF encapsulated antenna, the 8136 radar sensor is ideal for this application.

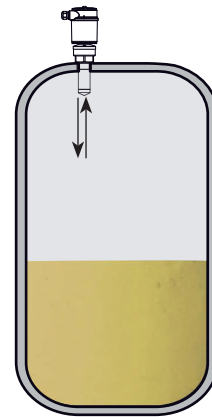

### ■ Open flumes

Flow measurement for heavy demands:

Radar sensors like the Type 8136 are also suitable for flow measurement in open flumes. For wastewater treatment in chemical plants, where wastewater temperatures change drastically or where solvents are contained in the wastewater, the use of radar sensors is recommended.

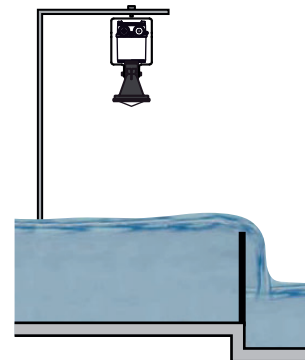

## Principle of operation

The radar transmitter consists of an electronic housing, a process fitting element the antenna and a sensor. The antenna emits short radar pulses with a duration of approximate 1 ns to the measured product. These pulses are reflected by the product surface and received by the antenna as echoes. Radar waves travel at the speed of light. The running time of the radar pulses from emission to reception is proportional to the distance and hence to the level. The determined level is converted into an output signal and transmitted as an measured value.

The transmitter can be adjusted with:

- the program module with display
- the suitable Bürkert DTM in conjunction with adjustment software according to the FDT/DTM standard, e.g. PACTware™ and PC.
- a HART handheld

The entered parameters are generally saved in the transmitter Type 8136. Optionally, parameters may also be uploaded and downloaded with the program module with display or in PACTware™

### ▶ Set up with program module with display

The program module with display can be inserted into the transmitter and removed again at any time. It is not necessary to interrupt the power supply. The transmitter is adjusted via the four keys of the program module with display.

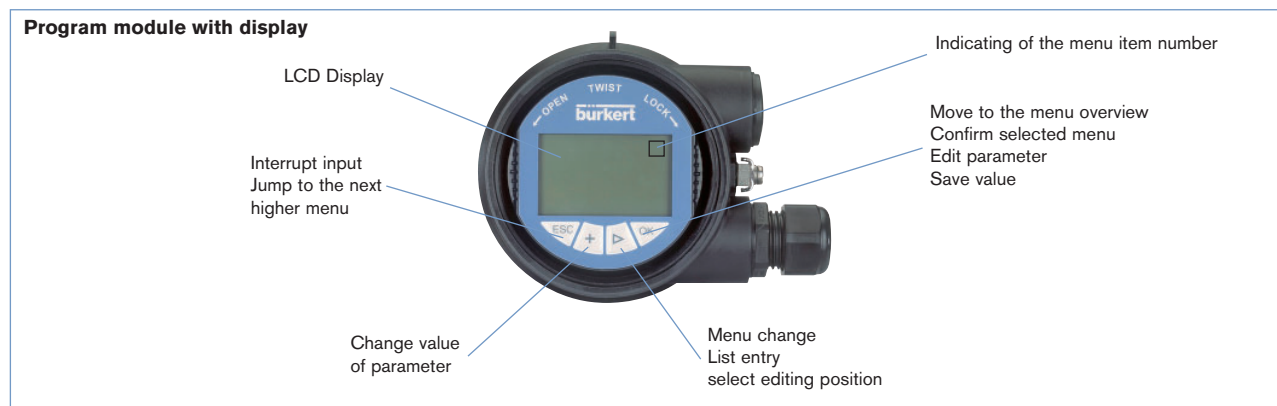

### ▶ Set up with PACTware™ / DTM and HART communication

The transmitter can be operated directly on the instrument via PACTware™ or via the HART signal on the signal cable. An interface adapter is necessary for the adjustment with PACTware™. For the setup of the Type 8136, DTM-Collection in the actual version must be used. The basic version of this DTM Collection incl. PACTware™ is available as a free-of-charge download from the Internet at [www.burkert.com](http://www.burkert.com).

Connecting the PC via HART to the signal cable

1. Transmitter 8136
2. HART-USB Modem
3. Resistance 250 Ohm

Necessary components :

- Transmitter 8136
- PC with PACTware™ and suitable Bürkert DTM
- HART-USB Modem from the market
- Resistance approx. 250 Ohms
- Power supply unit

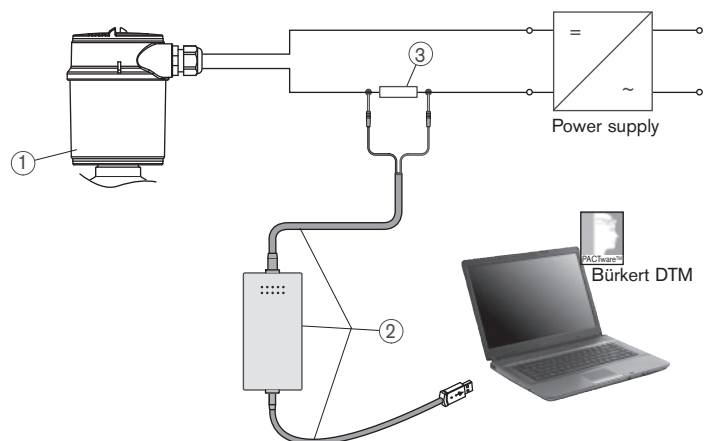

Dimensions [mm]

Encapsulated horn antenna version

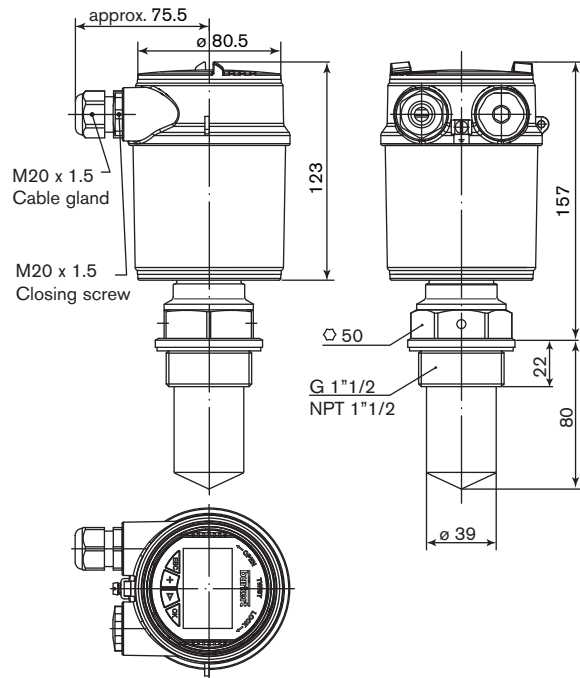

Plastic horn antenna version

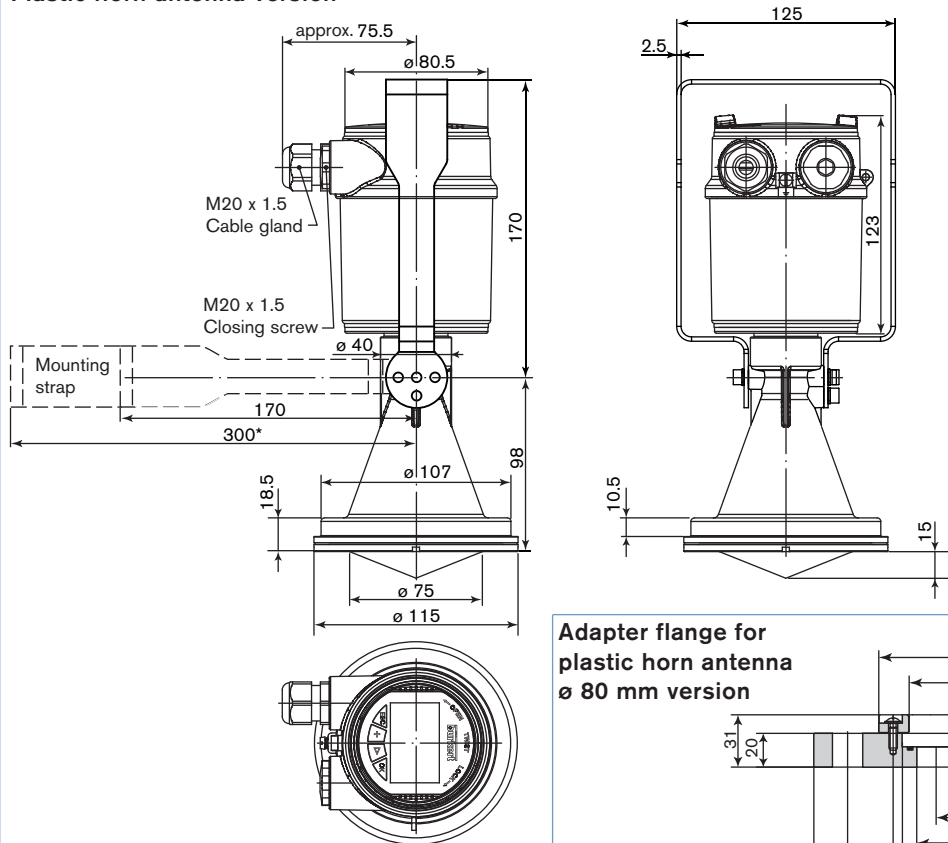

Adapter flange for plastic horn antenna  $\varnothing 80$  mm version

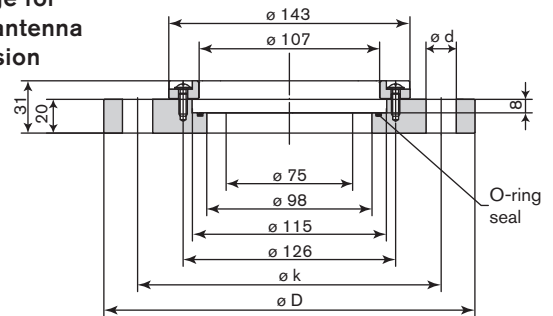

Flange	$\varnothing D$	$\varnothing k$	$\varnothing d$	Number of hole
DN100 PN16	220	180	18	8 x 45° (=360°)
ASME (ANSI B16.5) 4" 150 psi	228.6	190.5	19.1	8 x 45° (=360°)

\* the strap is to order separately

## Ordering chart for compact transmitter Type 8136

Specifications	Voltage supply	Output	Antenna version	Process connection	Electrical connection	Item no. without program module no display
Standard version	14-36 V DC	4-20 mA/HART (2 wires)	Encapsulated horn - 40 mm	G 1" 1/2	Cable gland M 20 x 1.5	560 146
				NPT 1" 1/2	Cable gland M 20 x 1.5	560 148
			Plastic horn - 80 mm	Mounting strap or adapter flange	Cable gland M 20 x 1.5	560 150
Ex version - ATEX approval	14-30 V DC	4-20 mA/HART (2 wires)	Encapsulated horn - 40 mm	G 1" 1/2	Cable gland M 20 x 1.5	560 147
				NPT 1" 1/2	Cable gland M 20 x 1.5	560 149
			Plastic horn - 80 mm	Mounting strap or adapter flange	Cable gland M 20 x 1.5	560 151

 **Further versions on request**

Please also use the "request for quotation" form on page 6 for ordering a customized transmitter. [go to page](#)

**Process connection**

Clamp 2", 3"  
bolting DN50, DN80 PN3, DIN 11851 / 316L  
without compression flange,  
with compression flange DN80PN16, ANSI3", JIS DN80 10K / PPH  
adapter flange DN150PN16 FKM /PPH  
ANSI4" 150PSI FKM /PPH  
ANSI6" 150PSI FKM /PPH  
JIS DN100 10K FKM /PPH  
JIS DN150 10K FKM /PPH

## Ordering chart - accessories for transmitter Type 8136 (has to be ordered separately)

Specifications	Item no.
Set with 2 reductions M 20 x 1.5 / NPT1/2" + 2 neoprene flat seals for cable gland + 2 screw-plugs M 20 x 1.5	551 782
Set with a display and programming module, a transparent cover and a seal ring	559 279
Set with a transparent cover and a seal ring	561 006
Hart-USB Modem	560 177
Mounting strap 300 mm	559 839
Adapter flange DN100PN16 FKM / PPH	560 437
Adapter flange ASME (ANSI B 16.5) 4" 150 PSI FKM /PPH	560 436