

blackbox

Level 130

INSTRUCTION MANUAL



PULSAR

Process Measurement

BLACK BOX LEVEL 130 (FOURTH EDITION)

May 2007

Part Number M-130-004S

COPYRIGHT

© Pulsar Process Measurement Limited, 2003 -07. All rights reserved. No part of this publication may be reproduced, transmitted, transcribed, stored in a retrieval system, or translated into any language in any form without the written permission of Pulsar Process Measurement Limited.

WARRANTY AND LIABILITY

Pulsar Process Measurement Limited guarantee for a period of 2 years from the date of delivery that it will either exchange or repair any part of this product returned to Pulsar Process Measurement Limited if it is found to be defective in material or workmanship, subject to the defect not being due to unfair wear and tear, misuse, modification or alteration, accident, misapplication or negligence.

DISCLAIMER

Pulsar Process Measurement Limited gives nor implies any process guarantee for the this product, and shall have no liability in respect of any loss, injury or damage whatsoever arising out of the application or use of any product or circuit described herein.

Every effort has been made to ensure accuracy of this documentation, but Pulsar Process Measurement Limited cannot be held liable for any errors.

Pulsar Process Measurement Limited operates a policy of constant development and improvement and reserves the right to amend technical details as necessary.

TECHNICAL ENQUIRIES

Please contact Pulsar Process Measurement Limited for technical support.

COMMENTS AND SUGGESTIONS

If you have any comments or suggestions about this product, then please contact:

Pulsar Process Measurement Limited
Cardinal Building
Enigma Business Centre
Sandy's Road
Malvern
Worcestershire
WR14 1JJ
United Kingdom

Tel: 0870 6039112 (*International +44 870 6039112*)

Fax: 0870 6039114 (*International +44 870 6039114*)

Web Site: <http://www.pulsar-pm.com>

e-mail: info@pulsar-pm.com (general information)

e-mail: support@pulsar-pm.com (product support)

Contents

Chapter 1 Start Here	1
About this Manual	1
About the blackbox range	2
Functional Description	3
Product Specification	4
Chapter 2 Installation	6
Power Supply Requirements	6
Location	6
Dimensions	8
Terminal Connection Details	10
Voltage Selector and Fuse Location	12
Preparation for Operation	14
Maintenance	14
Chapter 3 How To Use Your blackbox Level System	15
PC Handheld Programmer (Standard)	15
Communication Port Configuration	16
Handheld Communicator (Optional)	16
Operating the Controls	17
Display	17
Keypad	18
Run Mode	20
LED's	21
Program Mode	21
How to Access Program Mode	21
Test Mode	23
LED's	24
Using the RS232 Serial Interface	24
Parameter Defaults	25
Factory Defaults	25
Chapter 4 Programming Guide	26
Level	26
Example 1 Level Measurement	26
Example 2 Alternating Control (pump down)	28
Chapter 5 Parameter Guide	30
Menu System Diagrams	30
Top Level Menu	30
Application Menu	30
Relays Menu	31
Data Logs Menu	31
Display Menu	32
Output Menu	32
Compensation Menu	32
Stability Menu	33
Echo Processing Menu	33
System Menu	34
Test Menu	35

Parameter Listing	36
Application Parameters	36
Operation	36
Dimensions	37
Remote Alarm	39
SMS Time.....	40
Relay Parameters	42
Relay Type.....	42
Alarms.....	43
Control	46
Common Parameters.....	48
Data Log Parameters	48
Temperature.....	48
Display Parameters	49
Options.....	49
Failsafe	49
Output Parameters.....	50
Range	50
Operation	51
Setpoint	51
Limits	51
Trim.....	52
Failsafe.....	52
Compensation Parameters	53
Offset.....	53
Temperature.....	53
Stability Parameters.....	54
Damping	54
Filters.....	54
Echo Processing Parameters.....	55
Transducer Status	55
System Parameters	56
Passcode.....	56
System Information	56
Date & Time	57
Daylight Saving Time	57
Test Parameters	61
Simulation.....	61
Hardware.....	62
Chapter 6 Troubleshooting.....	63
Parameter Record.....	64

Congratulations on your purchase of a Pulsar blackbox 130 Level System. This quality system has been developed over many years and represents the latest in high technology ultrasonic level measurement and control.

It has been designed to give you years of trouble free performance, and a few minutes spent reading this operating manual will ensure that your installation is as simple as possible.

About this Manual

It is important that this manual is referred to for correct installation and operation.

There are various parts of the manual that offer additional help or information as shown.



Tips

Tip

At various parts of this manual you will find tips to help you.

Additional Information

Additional Information

At various parts of the manual, you will find sections like this that explain specific things in more detail.

References

— See Also

References to other parts of the manual

About the blackbox range

The Pulsar blackbox is a non-contact Level Control System. It has been designed to provide a new concept in low cost maintenance-free fit and forget level measurement without any compromise on performance.

Housed in an IP67/Nema 6 enclosure the product line is ideally suited to applications where level monitoring, reporting, control or logging is required without the need for a local display.

The blackbox level system is available in a variety of different versions offering a wide choice of output options.

The blackbox is very easy to use and may be calibrated quickly and simply via a laptop, using the software supplied with the unit, or alternatively by using the optional hand held calibrator, which connects to the unit via the RS232 interface, and provides an onboard LCD display.

All models of the blackbox range can be used with any of the extensive range of Pulsar dB transducers for distances up to 40m.

The blackbox range is designed to provide you with highly reliable measurement in a robust and functional package that is easy to use and low in cost.



Functional Description

The **blackbox** ultrasonic Level System sends a transmit pulse to the transducer, which emits an ultrasonic pulse perpendicular to the transducer face, and the returned echo is sent back to the **blackbox**. The time taken to receive the echo is measured and the distance from the transducer face to the surface being monitored is calculated.

The **blackbox** utilises the unique DATEM software (Digital Adaptive Tracking of Echo Movement). This is an entirely new digital mapping technique developed especially for the Pulsar's range of ultrasonic level and control systems. It gives the system edge when identifying the "true target level" in the face of competing echoes from pipes, pumps or other obstructions.

The **blackbox** can measure from zero to 40m from the transducer to the surface being monitored, dependent on the transducer used.

The **blackbox** can measure **level, space or distance** and provide a representative output. There are two user definable relays, with individual setpoints, which can be programmed to activate alarms or control functions, a mA output that can be used for remote indication purposes and a RS232 port, so that the **blackbox** can be programmed or monitored remotely by a PC or other equipment.

The **blackbox** can be programmed either by PC, via the RS 232 Serial Interface, using the supplied software (standard) or by hand held calibrator (optional) which is connected to the **blackbox** via the RS 232 interface.

All the parameters are stored in non-volatile memory, so are retained in the event of power interruption.

Product Specification

Physical

Wall Mount

Outside dimensions

Weight

Enclosure material/description

Cable entry detail

Transducer cable extensions

Maximum separation

Environmental

IP Rating (Wall)

Max. & min. temperature (electronics)

Flammable atmosphere approval

CE approval

Performance

Accuracy

Resolution

Max. range

Min. range

Rate response

Echo Processing

Description

Outputs

Analogue output

Serial Port

Volt free contacts, number and rating

Programming

PC programming (standard)

Remote programming (optional)

Programming security

Programmed data integrity

130 x 130 x 60 mm

Nominal 0.65 kg

ABS base with Polycarbonate lid,
flammability rating UL94HB

underside fitted with 3 x M20, nylon cable
glands suitable for 6 – 12mm cable

2-core screened

1000 m

IP66/67

-20 °C to +50 °C

Safe area: compatible with approved dB
transducers (see transducer spec' sheet)

EMC approval to BS EN 50081-1:1992 for
emissions and BS EN50082-2:1995 for
immunity,
and to BS EN61010-1:1993 for low voltage
directive

0.25% of the measured range or
6 mm (whichever is greater)

0.1% of the measured range or 2 mm
(whichever is greater)

Dependant on transducer (maximum 40m
dB40)

Dependent upon transducer (minimum zero
dB Mach 3)

fully adjustable

DATEM (Digital Adaptive Tracking of Echo
Movement)

Isolated or non-isolated output of 4-20 mA or
0-20 mA into 1K Ω (user programmable and
adjustable) 0.1% resolution

RS232 for programming and data extraction

2 form "C" (SPDT) rated at 2A at 240V AC

via RS232 using supplied software
via RS232 using optional hand held
calibrator

Via passcode (user selectable and
adjustable)

Via non-volatile RAM

Supply

Power supply

115V ac + 5% / -10% 50/60 Hz,
230V ac + 5% / -10% 50/60 Hz,
dc 10 - 28V
10W maximum power (typically 5W)
50 mA at 200-240 VAC
100 mA at 90-120 VAC

Fuses

Remote Communicator

Power Supply

Power supplied via blackbox RS232 interface.

Pulsar Process Measurement Limited operates a policy of constant development and improvement and reserve the right to amend technical details as necessary.

Power Supply Requirements

The blackbox can operate from AC supply or from a DC battery. The AC is either 115V $\pm 5\%$ /-10% 50/60Hz or 230V $\pm 5\%$ /-10% 50/60Hz, depending on the position of the selector switch. The DC is 10-28V. In all cases the blackbox will typically consume 5W of power, with a maximum of 10W.

Location

All electronic products are susceptible to electrostatic shock, so follow proper grounding procedures during installation.

The blackbox level controller must be mounted in a non-hazardous (safe) Area, and the transducer fitted in the hazardous area.

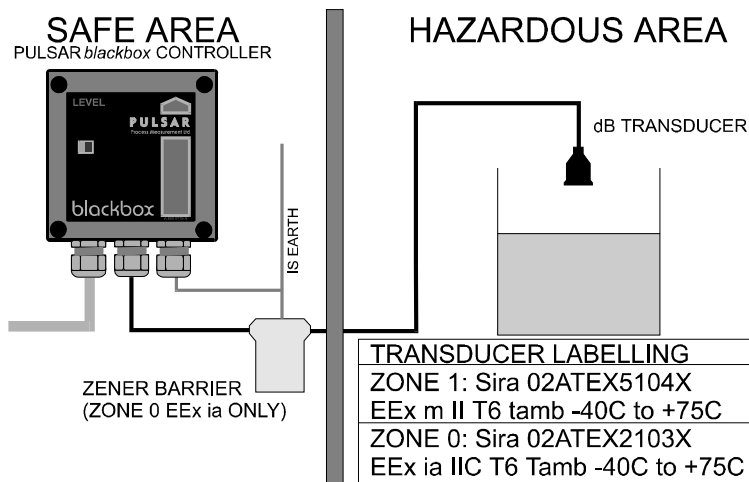

When choosing a location to mount the enclosure, bear in mind the following:

- Easy access to the enclosure is maintained.
- The mounting surface is vibration-free.
- The ambient temperature is between -20°C and 50°C .
- There should be no high voltage cables or inverters close by.

Dimensions

The dimensions of the mounting holes are as shown below.

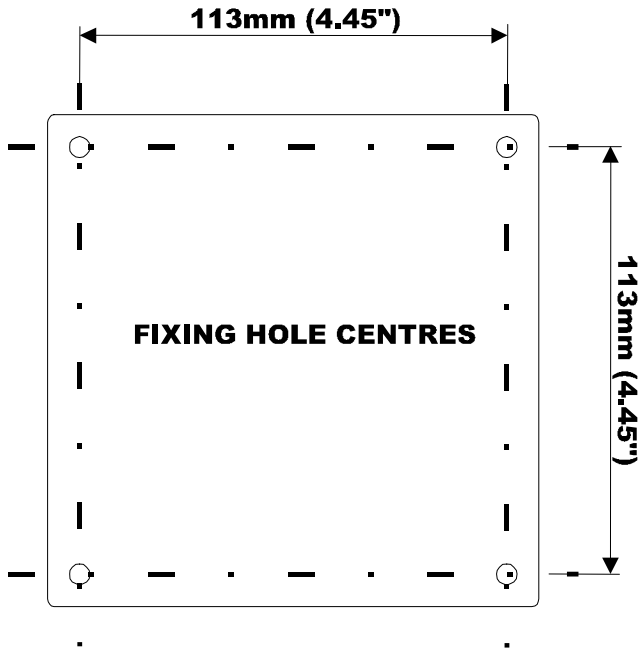

The blackbox should be mounted by drilling four holes suitable for size 8 screws (length and type to suit your application) And fix all four screws by removing the top cover to access the pre-moulded mounting holes which are located in the base of the enclosure under the lid retaining screws.

The full dimensions of the enclosure are as shown below.

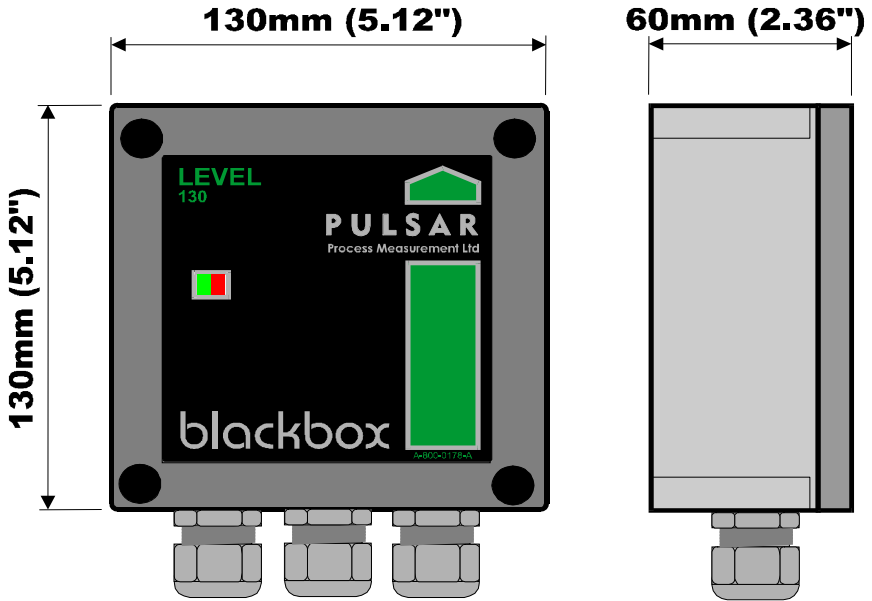

Cable Entry

There are 3 x M20 cable glands, suitable for 6 – 12mm cables, fitted to the base of the blackbox enclosure.

Terminal Connection Details

The terminal strip is as detailed below. There is also a wiring diagram attached to the board directly underneath the terminal strip.

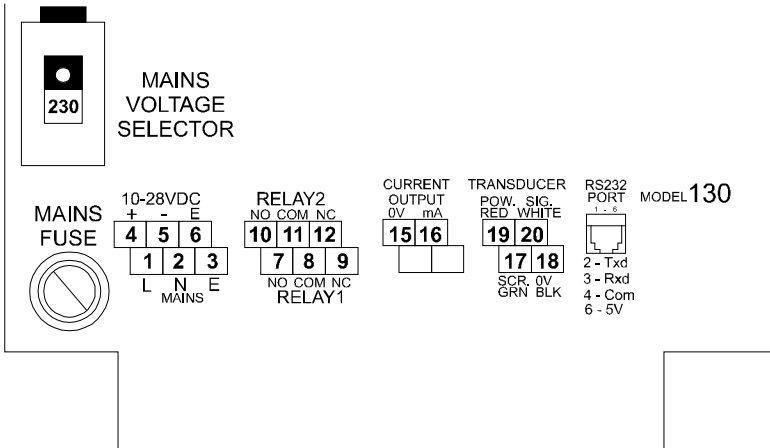

Terminal Connections

Power

The blackbox can operate from mains AC and automatically from a DC power source or battery backup, in the event of power failure, or can be operated permanently from DC or batteries.

Transducer

The transducer should be installed, and connected, in accordance with the installation instructions contained in the Transducer User Guide.

The entire range of, standard dB transducers are certified for use in hazardous areas and different models, for each, are available for use in Zone 1 or Zone 0.

Wire the transducer to the blackbox transducer terminals as detailed below:

Red = Power (Terminal 19)

White = Signal (Terminal 20)

Black = 0 volts (Terminal 18)

Green (screen) = SCR (Terminal 17)

When using 2 core screened extension cable, the Black and Green wires of the transducer should be connected to the screen of the extension cable and connected to the 0 volts terminal (Terminal 18).

For **Zone 1** applications a transducer certified to **Sira 02ATEX5104X** is used, and must be supplied via a 4000A breaking fuse, which is fitted as standard to the blackbox level controller.

For **Zone 0** a transducer certified to **Sira 02ATEX2103X** is used, which must be connected to the blackbox via an external Zener barrier.

See transducer label for certification details.

Relay Outputs

The two relays can be programmed to a variety of alarm and control functions. The relay contacts are all rated at 2A at 240V AC. All connections should be such that the short circuit capacity of the circuit to which they are connected, is limited by fuses rated so that they do not exceed the relay rating.

Current Output

This is an isolated mA output of 4 - 20mA or 0 - 20mA, and the load should not exceed 1K Ω .

RS232 Serial Interface

The serial interface is used to programme the blackbox either via a PC (standard) using the software supplied or alternatively using the hand held calibrator (optional).

Voltage Selector and Fuse Location

The voltage selector switch and AC mains power fuse is located, on the bottom board to the left and above of the power input terminals, as previously illustrated in the Terminal Connections Detail drawing.

Important Information

Before applying AC power (mains), make sure you have correctly selected the voltage selector switch which is located to the left and above of the mains supply input terminals, as illustrated in the Terminal Connections Detail drawing.

Please note that all units are supplied set to 230 volts AC for safety reasons.

Never operate the blackbox with the cover removed.

An external switch or circuit breaker should be installed near to the blackbox to allow the supply to be removed during installation and maintenance. In addition, the relay contacts should also have a means of isolating them from the blackbox..

Interconnecting cables must be adequately insulated for IEC 664 Category II installations. Strip back 30 mm of the outer insulation of the cable. Strip 5 mm of insulation from the end of each conductor. Twist all exposed strands of the conductor together. Insert the stripped conductor into the terminal block as far as it will go and tighten the terminal block screw. Ensure that all strands are firmly clamped in the terminal block and that there is no excess bare conductor showing, and no stray strands.



DON'T FORGET

Make sure you move the voltage selector switch to the correct position for your supply.

Important Information

If the equipment is installed or used in a manner not specified in this manual, then the protection provided by the equipment may be impaired.

Preparation for Operation

Before switching on, check the following:

- ✓ The blackbox is mounted correctly and is in a 'safe' area.
- ✓ The power supply is correctly installed.
- ✓ The voltage selector switch is in the correct position.
- ✓ The relays are connected correctly.

Maintenance

There are no user serviceable parts inside your blackbox, except the mains power fuse. If you experience any problems with the unit, then please contact Pulsar Process Measurement for advice.

To clean the equipment, wipe with a damp cloth. Do not use any solvents on the enclosure.

Important Information

The unique DATEM software comes into operation as soon as power is applied, and is designed to monitor a **moving level** or **target** with the **transducer** in a **fixed position**.

If, after any period of use, it should become necessary to move the transducer, for any reason, from its original operating position, switch off the blackbox, before proceeding, to prevent any undesirable updates to the DATEM trace. If after moving the transducer the reading is not as expected please refer to **Chapter 6 Troubleshooting** .

In order to view or change parameter values one of the following methods must be used:

PC Handheld Programmer (Standard)

Your blackbox 130 comes complete with the PC Handheld Programmer software, contained on CD. Insert the CD into the CD drive of the PC intended to be used to carry out the programming of the blackbox and install the software, following the on screen instructions. Once the software is installed connect the computer via its serial port to the blackbox RS232 serial interface RJ11 connector, located on the terminal connector strip, inside the blackbox enclosure. Double click the 'Handheld Programmer' icon, installed on your desktop and the PC will automatically connect to the blackbox. Once connected you will briefly see the message illustrated on the display below which, after connecting successfully, will then change to display the current measurement, dependent on mode and measurement unit's chosen. When using the PC Handheld Programmer software, keypad input can be achieved by using a 'mouse' or similar device to place the cursor over the relevant key followed by a 'left' click, alternatively numeric detail can be entered directly from the PC keyboard as can 'ENTER' and 'CANCEL' (Esc. Key).



Communication Port Configuration

If the PC Handheld Programmer fails to connect to the blackbox unit you may need to change the communications port that is being used, to do this 'right click' on the PC Handheld Programmer keypad and a 'pop up' menu will appear allowing you to select the appropriate communications port.

Handheld Communicator (Optional)

The optional Handheld communicator can be used to programme any number of blackbox units and works in a similar way to the PC Software. Connect the Handheld Communicator, with the cable supplied, to the RS232 interface via the RJ11 connector located on the terminal connector, inside the blackbox enclosure. Once connected you will briefly see a message, similar to that as seen when using the PC Software which, after connecting successfully, will then change to display the current measurement, dependent on mode and measurement unit's chosen.



Operating the Controls

Display

The display on both the PC Programming Software (standard) and the Hand Held Calibrator (optional) are identical, and when connected to the **blackbox** via the RS232 interface, provides information on the current mode of operation.

Whilst in the Run Mode it will display the current level reading and its units of measure, along with status messages with regards to the Transducer, Echo reception and Fail Safe Mode. When in the Program mode the display is used to read information on the Menu System, Parameter Number and parameter details and values, which can be entered. During Test Mode the display is used to monitor the simulated level.

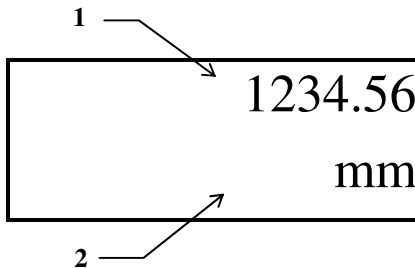







- 1) **Main Display**, 6 digit numeric display:
Run Mode, current measurement displayed, dependent on mode and measurement unit's chosen, and value of Hot Key function selected.
Program Mode, displays parameter number and values entered for parameters.
Test Mode, displays simulated level.
- 2) **Auxiliary Display**, scrolling twelve digit alpha numeric display
Run Mode, displays measurement units (P104), status messages on signal and transducer, detail of Hot Key function selected.
Program Mode, displays Menu and Sub Menu headings, parameter details and options.

Keypad





Hot Keys

There are five hot keys on the keypad, which can be used to quickly access common parameters for viewing only, while in Run Mode. Pressing the hot key once will display the first parameter, then repeated pressing will display subsequent parameters, as available, then the **blackbox** reverts to Run Mode. In program mode, they have different functions, the functions are shown below.

Hot Key	Run Mode	Program Mode
	Not used with blackbox 130.	Not used with blackbox 130.
	Echo Confidence/echo strength/H.A.L.L./average & peak noise/temperature.	Not used with blackbox 130.
	Not used with blackbox 130.	Reset parameter to default setting.
	Instantaneous mA output.	Not used with blackbox 130.
	Gives readings of Distance, Level or Space in units of measurement.	Not used with blackbox 130.
	Not used with blackbox 130.	Takes you to the last parameter edited, when you first enter program mode.
	Gives details of unit type, software revision and serial number.	Enter Decimal Point.

Menu Keys

The menu keys are used to navigate around the built in menu system and have the following functions:

Menu Key	Function
 	1) Arrow keys for moving left and right around the menu system. 2) Used in test mode to simulate the level moving up and down.
	1) Used to confirm each action (for example select a menu option) or when entering a parameter number or value. 2) Used to confirm questions asked by your blackbox such as before restoring factory defaults.
	Used to navigate up a level in the menu system, and back to run mode. Used to cancel a value entered in error.

Numeric Keys

These keys are used for entering numerical information during programming.

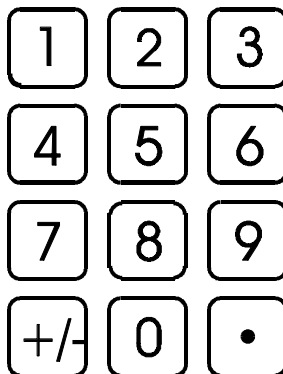

There are two main operating modes for your blackbox, **Run Mode** and **Program Mode**. There is also a **Test Mode**, used for checking the set-up. All modes are now described.

Run Mode

This mode is used once the blackbox has been set up in program mode. It is also the default mode that the unit reverts to when it resumes operation after a power failure.

When the blackbox is switched on for the first time, it will provide an output proportional to the distance from the transducer to the target, in metres. All relays by default are switched off.

If either the PC Programming Software (standard) or the Hand Held Calibrator (optional), are connected to the blackbox, via the RS232 interface, whilst the blackbox is in the RUN mode then the current measurement will be displayed, dependent on mode and measurement unit's chosen.

After programming is complete, any relays that are set will operate when the measurement reaches the relevant setpoint.

LED's

There are two LED's which can be seen through the lid, of the blackbox enclosure, which will indicate the operational **status** of the unit whilst in **RUN** mode, as follows:

LED 1 Green	LED 2 Red	Run Mode
Off	Off	No power to unit
Constant On	Constant On	Internal Error
Slow Flashing	Slow Flashing	Transducer fault
Off	Slow Flashing	Failed Safe /Loss of Echo
Slow Flashing	Off	Healthy signal unit working normally.

Program Mode

This mode is used to set up the blackbox or change information already set. You must use either the PC Software supplied (standard) or alternatively the unit can be set up with a Hand Held Calibrator (optional), both of which must be connected to the blackbox via the RS 232 Serial Interface.

Entering a value for each of the parameters that are relevant to your application provides all the programming information.

How to Access Program Mode

To enter **program mode**, you simply enter the passcode, via the keypad on the PC Programming Software (standard) or the Hand Held Calibrator (optional), followed by the **ENTER** key. The **default passcode** is **1997**, so you would press the following:



Note

There is a time-out period of 15 minutes when in **program mode**, after which time **run mode** will be resumed if you do not press any keys.

There are two means of editing parameters, directly or using the menu system. Each is now described.

Using The Menu System

The menu system has been designed to make the changing of parameters very simple. There are two levels of menu: **Main Menu** and **Sub Menu**.

On the display there is a line of text that shows the menu system. Pressing the arrow keys scrolls the display between the top-level menu items, (as shown below, starting at Quick Setup).

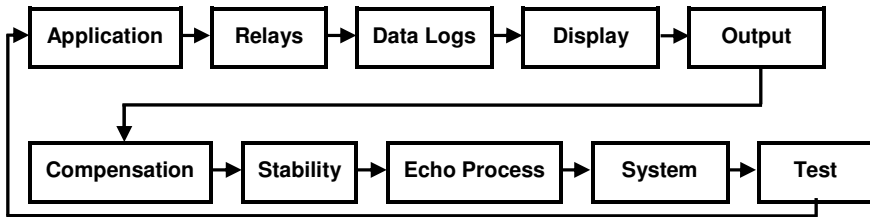

As you press the cursor keys to scroll left and right between these, you can press **ENTER** at any time to select it and take you to the sub-menu.

Each of these options, along with their sub-menus are described in Chapter 5, **Parameter Guide**. When you move down into the sub-menu, you can scroll round using the arrow keys, press **ENTER** to go to the required section of parameters.

Once you have reached the relevant section, scroll through the parameters, and enter the necessary information. To enter the information, use the numeric keys and press **ENTER** and you will see the message “**Saved!**”, if you press **CANCEL**, then no change will be made, and the message “**Unchanged!!**” will be displayed.

When you have finished, press **CANCEL** to go back to the previous level. When you have reached the top level, then the blackbox will ask for confirmation before allowing you to go back into run mode. This is done by pressing **ENTER** at the display prompt.

Directly Editing Parameters

If you already know the number of the parameter, that you wish to look at or edit, simply type the number in at any time while you are in the menu system. Thus, if you are in either the menu or sub-menu level by pressing a numeric key, you can enter the parameter number directly and jump straight there. You cannot type a parameter number whilst at parameter level, only at one of the two menu levels.

When you are at a parameter, the text line rotates automatically displaying the parameter name, number, the applicable units and the maximum and minimum figure you can enter. The top line shows the value you are setting.

Once you have accessed a parameter, you can either just look at it, or change it.

Once a parameter has been changed, press **ENTER** and you will see the message “**Saved!**”. If you press **CANCEL**, then no change will be made, and the message “**Unchanged!!**” will be displayed.



TIP

You can jump straight to the last parameter you edited, by pressing ‘+/-’ when you first enter program mode.

Test Mode

Test mode is used to simulate the application and confirm that all parameters and relay setpoints have been entered as expected. During simulation, there is a choice of whether the relays will physically change state (hard simulation) or not (soft simulation), the LED’s will always change state to indicate that the relay setpoints have been activated, and the mA output will change in accordance to the chosen mode of operation. If you wish to test the logic of the system that the **relays are connected** to then select **hard simulation**, but if you **don’t want to change the relay state**, then select a **soft simulation**.

There are two simulation modes, **automatic** and **manual**. **Automatic** simulation will move the level up and down between empty level and maximum span, whereas **manual** simulation will allow **you** to move the level up and down using the arrow keys.

To enter simulation, first go to **program mode**. Then, using the menu system, select menu item ‘**Test**’ then sub-menu item ‘**Simulation**’. Simply change the value of the parameter **P980** to one of the following:

- 1= Manual soft simulation
- 2= Automatic soft simulation
- 3= Manual hard simulation
- 4= Automatic hard simulation

To return to program mode, press **CANCEL** and test mode will end.

When in **manual** simulation, by default test mode will move the level by 0.25m steps. Altering the **increment (P981)** will change this value.

In **automatic** mode, the rate at which the level moves up and down is set by the **increment (P981)** in metres and the **rate (P982)** in minutes, which can be changed to make the level move up and down faster. E.g. if **increment (P981)** is set for 0.25m and **rate (P982)** is set to 1 min then the level will increase or decrease at a rate of 0.25m/min. To make the simulated level move slower, decrease the value in **increment (P981)** or increase the value in **rate (P982)**. To make the simulated level move faster, increase the value in **increment (P981)** or decrease the value in **rate (P982)**.

LED's

There are two LED's which can be seen through the lid, of the blackbox enclosure, which will indicate the **status** of the **relays** whilst in **simulation** as follows:

Green	Red	Run Mode
Off	Off	Relays are in there OFF state.
Constant On	Off	Relay 1 in its ON state
Off	Constant On	Relay 2 in its ON state

Using the RS232 Serial Interface

The RS232 serial interface is used to program the blackbox, and obtain information using a PC or other computer equipment. To do so, the settings for control are as follows: **baud rate 19,200, 8 data bits, no parity, 1 stop bits.**

The device should be connected to the RS232 Interface via the RJ11 connector as shown in **Chapter 2 Installation.**

Parameter Defaults

Factory Defaults

Factory Defaults

When first installing the **blackbox**, or subsequently moving or using the unit on a new application, before proceeding to program the unit for its intended application it is recommended that you ensure that all parameters are at their default values by completing a **Factory Defaults P930**, as described in Chapter 5 **Parameter Guide**.

When you first switch the **blackbox** on it will provide an output proportional to the **distance** from the face of the transducer to the surface. All relays are set OFF.

The **date** (P931) and **time** (P932) in the **blackbox** were set at the factory, but may need checking, and amending if, for example the application is in a time zone other than GMT, see Chapter 5 **Parameter Guide** for full details.

TIP



In some applications it is simplest to empty the vessel, take a reading from the **blackbox** for distance and then setup the empty level to this figure.

Once you are satisfied with the installation, and the **blackbox** is reading what you would expect in terms of distance from the face of the transducer to the material level, then you can proceed with programming, for the intended application. It is sensible to program all of the required parameters at the same time. The system will be then set-up.

Note that the span is automatically calculated from the empty level, so the empty level should be entered first.

Level

Example 1 Level Measurement

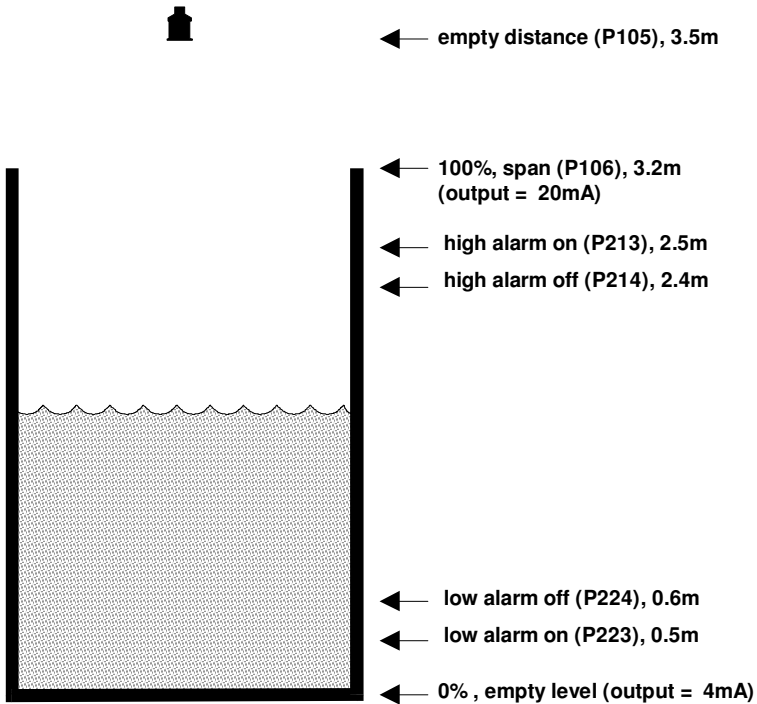

In this example, the blackbox and dB6 is being used to monitor a moving level within a vessel and is required to provide a 4 to 20mA output proportional to the level, over a range of 3.2m. In addition when the level rises to 2.5m, Relay '1' is required to give a high alarm and rest when the level falls to 2.4m. In the event that the level should fall to 0.5m then Relay '2' is to give a low alarm and reset once the level rise to 0.6m.

To program the blackbox for this **Example**, proceed as follows.

Access the **Program Mode**

Key in the **passcode** 1997 and press **ENTER**

Using the menu system access the parameters, as detailed below, and select the relevant options and **ENTER**.

Top Level Menu	Sub Menu	Parameter Detail	Selected Value
Application	Operation	P100 Mode	2 = Level
		P101 Xducer	2 = dB6
	Distances	P104 Measnt Units	1 = metres
		P105 Empty Level	3.5
	P106 Span	3.2	
Relays	Relay 1	P210 Relay 1 Type	1 = Alarm
		P211 R1Function	1 = Level
		P212 R1 ID	2 = High
		P213 R1 Set 1	2.5
		P214 R1 Set 2	2.4
	Relay 2	P220 Relay 1 Type	1 = Alarm
		P221 R1Function	1 = Level
		P222 R1 ID	4 = Low
		P223 R1 Set 1	0.5
		P224 R1 Set 2	0.6

Programming is now complete and the unit can be returned to the run mode, press **CANCEL** until **Run Mode?** Is displayed on the display press **ENTER**, and the blackbox will return to the **Run Mode**.

Note

The 4 to 20mA output will be automatically set to the value of P106 Span, with 4mA being representative of 0% of Span (zero level) and 20mA 100% of Span (Full level).

Example 2 Alternating Control (pump down)

A sump is typically used to temporarily hold water or effluent, and when the level reaches a specific point, the sump is pumped down, with the fluid being transferred to another process.

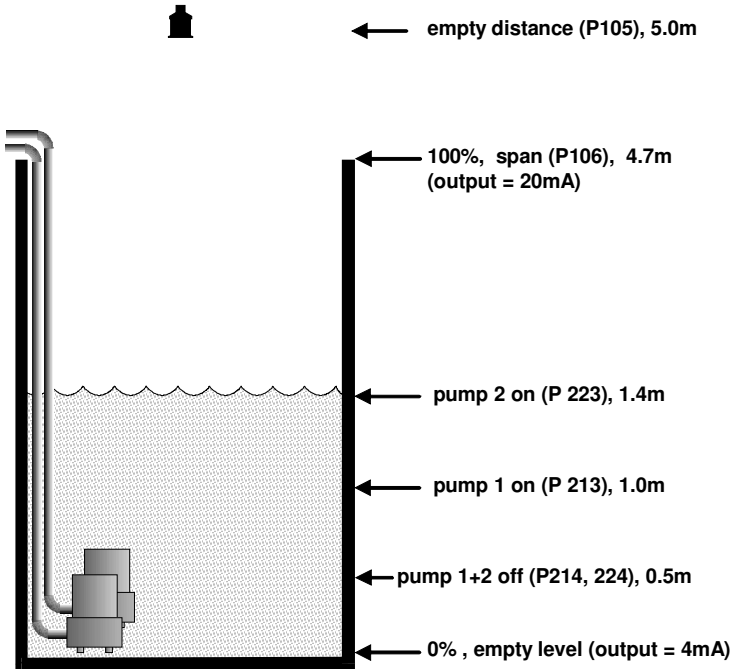

In this example a blackbox with dB6 is being used to control pumps on a **pump down** application, there are two pumps, and the **duty** pump is to be **alternated** between the pumps.

This will operate as follows. During normal operation, **pump 1** will come on at 0.8 m, and pump down to 0.5 m. The setpoints are then shifted to **pump 2**, which will come on first next time.

During peak periods, when **pump 1** cannot cope, **pump 1** will come on at 1.0m, **pump 2** will come on at 1.4 m, and pump down to 0.5 m. The setpoints are then shifted to **pump 2**, which will come on **first next time**.

The 4 to 20mA output will be representative of level.

To program the blackbox for this **Example**, proceed as follows.

Access the **Program Mode**

Key in the **passcode** 1997 and press **ENTER**

Using the menu system access the parameters, as detailed below, and select the relevant options and **ENTER**.

Top Level Menu	Sub Menu	Parameter Detail	Selected Value
Application	Operation	P100 Mode	2 = Level
		P101 Xducer	2 = dB6
	Distances	P104 Measnt	1 = metres
		P105 Empty Level	5.0
		P106 Span	4.7
Relays	Relay 1	P210 Relay 1	2 = Control
		P211 R1Function	1 = General
		P212 R1 ID	2 = Alternate
		P213 R1 Set 1	1.0
		P214 R1 Set 2	0.5
	Relay 2	P220 Relay 1	2 = Control
		P221 R1Function	1 = General
		P222 R1 ID	2 = Alternate
		P223 R1 Set 1	1.4
		P224 R1 Set 2	0.5

Programming is now complete and the unit can be returned to the run mode, press **CANCEL** until **Run Mode?** Is displayed on the display press **ENTER**, and the blackbox will return to the **Run Mode**.

Note

The mA output will be automatically set to the value of P106 Span, with 0 or 4 mA being representative of 0% of Span (zero level) and 20mA 100% of Span (Full level).

Chapter 5 Parameter Guide

This chapter describes all of the parameters contained in your blackbox.

Menu System Diagrams

Shown below is a set of charts to show you how all the various parts can be found using the menu system.

Top Level Menu

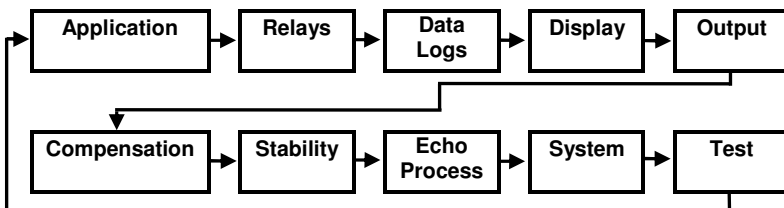

Application Menu

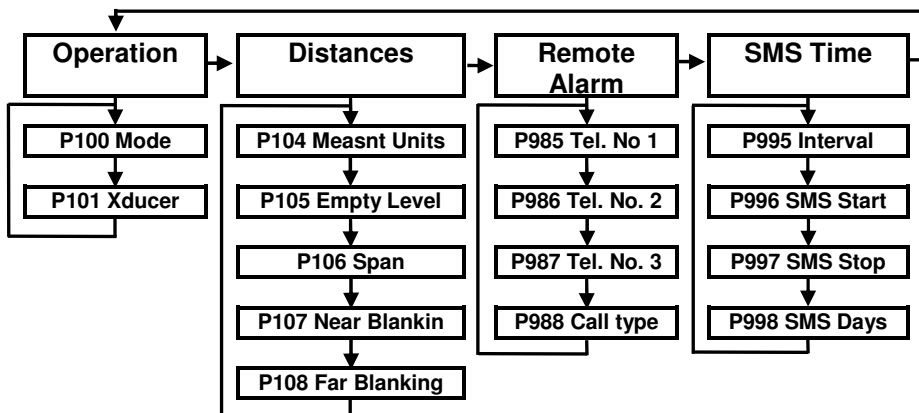

Relays Menu

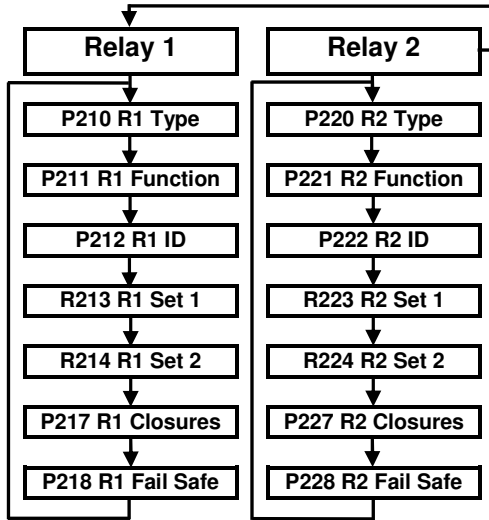

Data Logs Menu

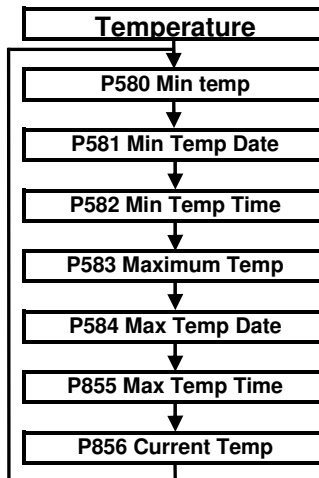

Display Menu

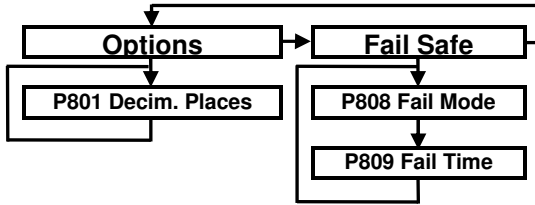

Output Menu

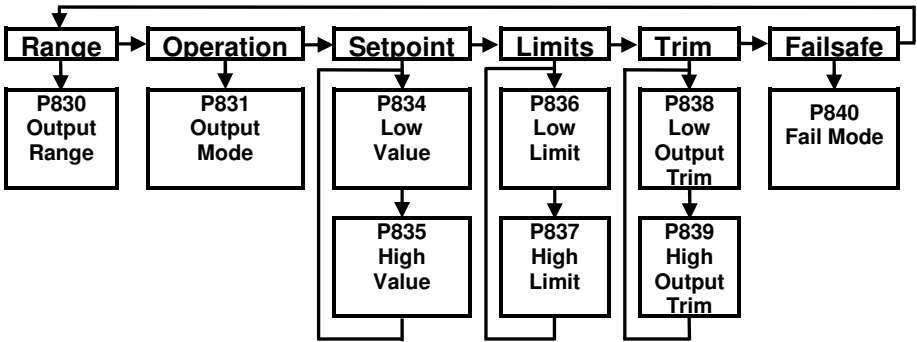

Compensation Menu

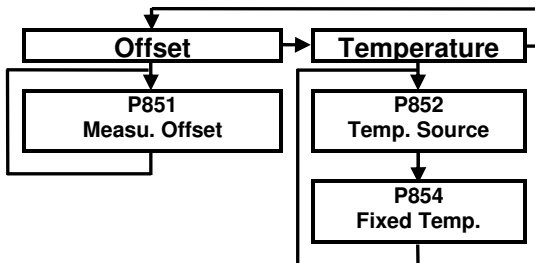

Stability Menu

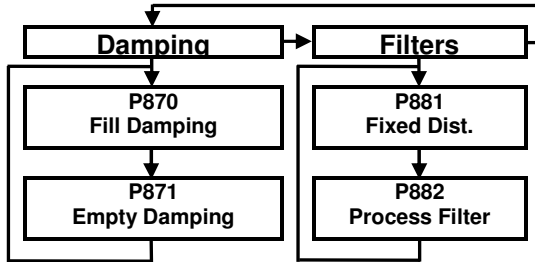

Echo Processing Menu

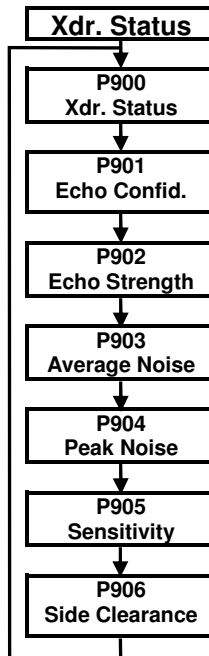

System Menu

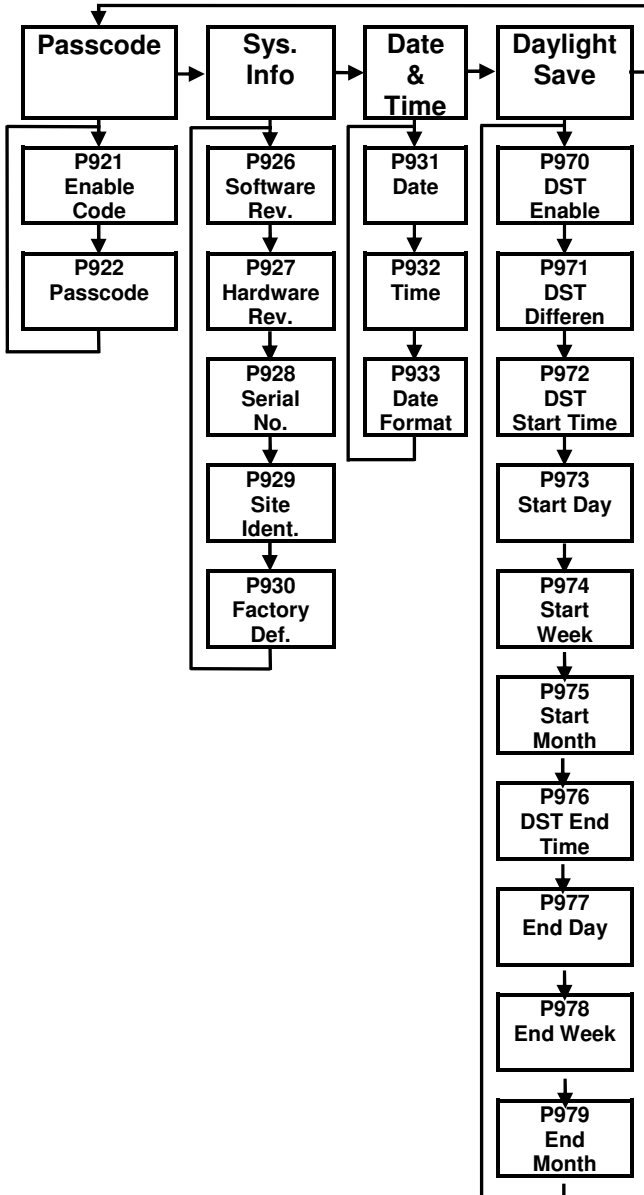

Test Menu

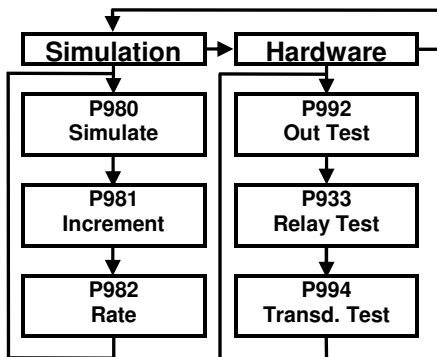

Parameter Listing

This section describes all of the parameters. Any parameter can be reset to its default, by pressing the  hot key, whilst in program mode.

Application Parameters

Operation

P100 Mode of Operation

This parameter sets the mode of operation, when in run mode, and can be set to one of the following:

Option	Description
1 = Distance (Default)	Display and Output relative to the distance from the transducer to the surface.
2 = Level	Display and Output relative to how full the vessel is.
3 = Space	Display and Output relative to how empty a vessel is.

P101 Transducer

This parameter should be set to the transducer being used with the unit, and can be set to one of the following:

Option	Description
1 = dB3	Transducer is a dB3.
2 = dB6 (Default)	Transducer is a dB6.
3 = dB10	Transducer is a dB10.
4 = dB15	Transducer is a dB15.
5 = dB25	Transducer is a dB25.
6 = dB40	Transducer is a dB40.
7 = dB56	Transducer is a dB56.

Dimensions

P104 Measurement Units

This parameter sets the units you want to use for programming and display

Option	Description
1 = metres (Default)	All units of measure are METRES
2 = cm	All units of measure are CENTIMETRES
3 = mm	All units of measure are MILLIMETRES
4 = feet	All units of measure are FEET
5 = inches	All units of measure are INCHES

P105 Empty Level

This parameter is to be set to the maximum distance from the face of the transducer to the empty point, in **P104 Measurement Units**. Note this value affects span as well, (see important information below), so should be set before span.

Important Information

When changing the Empty Distance (P105) you can also recalculate the values for the Span so that it equals the empty distance (P105) minus Near Blanking (P107) and the Relay Setpoints, so that they remain at the same percentage values of the empty distance as they were before you changed the empty distance (P105). You will be asked the question "Recalculate Span?" if you choose yes (enter 1), then the span will be recalculated. Any other answer will leave the span at its original value.

P106 Span

This parameter should be set to the maximum distance from the **Empty Level (P105)** to the maximum material level. It is automatically set to be equal to the **Empty Level (P105)** less the **Near Blanking** distance (**P107**), when you set the empty level.

P107 Near Blanking Distance

This parameter is the distance from the face of the transducer that is not measurable, and is pre-set to the minimum value dependant on the Xducer (P101) selected. It should not be set to less than this figure, but can be increased, typical to ignore close in obstructions.

Transducer	Near Blanking Distance
P101 = 1 Xducer is a dB3	Default Blanking Distance = 0.12m
P101 = 2 Xducer is a dB6	Default Blanking Distance = 0.3m
P101 = 3 Xducer is a dB10	Default Blanking Distance = 0.3m
P101 = 4 Xducer is a dB15	Default Blanking Distance = 0.5m
P101 = 5 Xducer is a dB25	Default Blanking Distance = 0.6m
P101 = 6 Xducer is a dB40	Default Blanking Distance = 1.2m
P101 = 7 Xducer is a dB56	Default Blanking Distance = 0.2m

P108 Far Blanking Distance

This is the distance (as a **percentage** of empty level **P105**) beyond the empty point that the unit will be able to measure, and by **default** is pre-set to plus **20%** of the **empty level**.

If the surface being monitored can extend beyond the **Empty Level (P105)** then the far blanking distance can be increased to a maximum of 100% of empty level.

This parameter is always entered as a % of empty level.

Remote Alarm

When a Modem is connected to the blackbox, via the RS232 port, (Consult Pulsar or your local distributor for further details), the following parameters are used to set up the blackbox so that when the level reaches a specific alarm point, as determined by the setting of the relay(s) the unit will dial and connect to a remote telephone number to provide details of the event.

P985 Tel. No.1

This parameter is used to enter the number of '0's that appear at the beginning of the telephone number to be dialled that is to receive the message.

Option	Description
0= None	No '0's present at the beginning of the telephone number to be dialled.
1 = Add 0 (Default)	1 '0' present at the beginning of the telephone number to be dialled.
2= Add 00	2 '0's present at the beginning of the telephone number to be dialled.

P986 Tel. No2

This parameter is used to enter to enter the next 6 digits, following the '0's, of the telephone number to be dialled. If there are less then 8 digits following the '0's then just enter the digits required, if there are more than digits following the '0's then enter the first 6 digits and then proceed to P987 and enter the remaining digits.

P987 Tel. No3

This parameter is used to enter any remaining digits of the telephone number to be dialled after completion of P985 and P986 above.

Example

Telephone number to be dialled is: 0 1234 123456

P985 Tel. No. 1 = 1(One '0' at the beginning of the telephone number)

P986 Tel. No. 2 = 123412 (The next 6 digits following the '0's).

P987 Tel. No. 3 = 3456 (Remaining digits of telephone number).

P988 Call Type

This parameter determines what type of connection is made via the modem.

Option	Description
0= Off (Default)	Remote alarm function is disabled
1 = Ring	This option initiates a connection to a remote modem/computer which will then allow remote communication with the unit. Please consult Pulsar or your local distributor for further details.
2= SMS	This option initiates a predetermined message which is sent to the remote telephone number detailing date and time the alarm was initiated, the site ID, alarm condition and level at the time the alarm was initiated.

SMS Time

The following parameters determine when and how often a SMS message is to be sent.

P995 SMS Interval

This parameter determines how often a SMS message will be sent. If the time interval is set at '0.00 mins.' then a SMS message will only be sent when an alarm condition occurs, when the time interval is set to anything other than zero then a SMS message will be sent at the relevant interval detailing the current level and/or any alarm condition present at that time.

Entered in minutes. Min = 0.000, Max = 1440mins. Default = 0.00 mins.

P996 Start Time

Sets the time at which the SMS Interval is to Start.

Entered as time. Min = 00:00, Max = 23:59 Default = 00:00

P997 Stop Time

Sets the time at which the SMS Interval is to Stop.

Entered as time. Min = 00:00, Max = 23:59 Default = 23:59

P998 SMS Days

This parameter will determine on which days the SMS message is active and is entered as a Boolean value equating to the total of the days that the SMS message is required to be active.

Mon	Tue	Wed	Thu	Fri	Sat	Sun
1	2	4	8	16	32	64

Add together any combination up to a maximum of 127 (every day).

Examples:

21 = Mon, Wed, Fri.,

31 = Mon to Fri.,

10 = Tue and Thu.

Relay Parameters

All relay related parameters are prefixed with a **2**** .

The second digit of the three figure parameter number denotes the relay number as follows:

21* parameters for Relay 1

22* parameters for Relay 2

The third digit selects specific parameters for the setting up of the relays, which can be selected individually and results in the following parameter numbers for each relay.

Relay 1 **210** to **218**

Relay 2 **220** to **228**

Relay Type

P210, P220 - Relay Type

This parameter defines what type each relay should be, see the table below or available options.

Option	Description
0= Not In Use (Default)	Relay not in use or programmed.
1= Alarm	Relay is programmed as an alarm relay, which will de-energise ON, and energise OFF. This will ensure an alarm is raised if the power fails to the unit.
2= Control	Relay is programmed as a control relay, which will energise ON, and de-energise OFF.

Alarms

P210, P220 =1 (Alarm)

The **second parameter** for each relay determines the **function** of the alarm.

P211, P221 - Relay Function

This parameter defines what **function** the **alarm** will respond to as follows.

Option	Description
0= Off (Default)	Relay will not operate.
1= Level	Alarm is based on the level in the vessel, and the type of level alarm (P212, 222) and two setpoints must be set (P213, 223 & P214, 224). Setpoints are entered in Display Units or % of span as referenced to Empty Level *.
2= Temperature	Alarm is based on the temperature, and the type of temperature alarm (P212, 222) and two setpoints must be set (P213, 223 & P214, 224). The temperature used depends on the temperature source selected (P852). Setpoints are entered in °C.
3= Loss of Echo	Alarm is raised if the Failsafe Timer (P809) expires. No setpoints are required.
4= Loss of Clock	Alarm is raised if the real time clock fails. No setpoints are required.

Note that the loss of echo and loss of clock will also be shown on the display as “LOST ECHO” and “LOST CLOCK” respectively.

The **third parameter** for each relay determines the **alarm ID** for the relay you wish to set.

P212, 222 - Relay Alarm ID

When P211, P221 = 3 (Loss of Echo) or 4 (Loss of Clock)
 This parameter has no function and will not be displayed.

When P211, P221 = 1 or 2

This parameter defines which **alarm type**, the relay should respond to, as follows.

Alarm ID	Description	Setpoints
1=General (Default)	Relay goes “ON” when the value reaches the ON setpoint and goes “OFF” when the value reaches the OFF setpoint.	P213, 223 is ON Setpoint; P214, 224 is OFF Setpoint
2= High	Relay goes “ON” when the value rises to the ON setpoint and goes “OFF” when the value lowers to the OFF setpoint.	ON> OFF Relay Setpoints P213, 223 and P214, 224 Setpoints, can be set in any order as the unit ‘knows’ that you are setting a high level alarm.
3= Hi-Hi	Same as 2 = High, but different identifier.	
4= Low	Relay goes “ON” when the value lowers to the ON setpoint and goes “OFF” when the value rises to the OFF setpoint.	ON<OFF Relay Setpoints P213, 223 and P214, 224. Setpoints, can be set in any order as the unit ‘knows’ that you are setting a low level alarm.
5= LoLo	Same as 4=Lo, but different identifier.	

Alarm ID	Description	Setpoints
6= In bounds	Relay goes “ON” if value is inside the zone between the two setpoints.	Relay Setpoints, P213, 223 and P214, 224 can be set in any order as the unit ‘knows’ that you are setting an in bounds alarm.
7= Out of bounds	Relay goes “ON” if value is outside the zone between the two setpoints.	Relay Setpoints P213, 223 and P214, 224 can be set in any order as the unit ‘knows’ that you are setting an out of bounds alarm.

The **fourth parameter** and the **fifth parameter** for each relay set the **Alarm “ON”** and **“OFF”** points. For a *high alarm* the **“ON”** is set **higher than “OFF”**. For *low alarm* then **“ON”** is set **lower than “OFF”**. See the appropriate **alarm ID**, table (**P212, 222**) for further information.

When P211, P221 = 3 (Loss of Echo) or 4 (Loss of Clock)

This parameter has no function and will not be displayed.

When P211, P221 = 1 or 2

P213, P223 - Relay Setpoint 1

Determines the **“ON”** or **“OFF”** point for the alarm according to the **ID** selected.

P214, P224 - Relay Setpoint 2

Determines the **“ON”** or **“OFF”** point for the alarm according to the **ID** selected.

Important Information

Setpoints are entered in values according to the **function** selected.

Level - entered in Display Units or % of span as referenced to Empty Level.

Temperature - entered in °C.

See the appropriate **alarm function**, table (P211, 221, 231) for further information.

Control

P210, P220 = 2 (Control)

When a relay is being set up as a **control** relay, the **second parameter** that will be displayed in the menu determines its **function**.

P211, P221 - Relay Function,

This function is used, where it is required to **energise** the relay to switch a device, such as a pump, **ON** and **de-energise** the relay to switch the device **OFF**.

Options	Description
0 = Off	Relay is always de-energised
1 = General	Relay will energise “ON” as set in Relay Setpoint 1 (P213, 223). And turns “OFF”, de-energises , as set in Relay Setpoint 2 (P214, 224).

Important Information

A control relay is started and stopped at the “ON” and “OFF” setpoints. To *control down* (reduce level) then set “ON” higher than “OFF”. To *control up* (increase level) then set “ON” lower than “OFF”. For relay 1 “ON” is P213, “OFF” is P214 and For relay 2 “ON” is P223, “OFF” is P224

The **third parameter** determines if the control is fixed or alternating.

P212, 222 Relay Control ID

P210, 220 = 2 (Control)

P211, 221 = 1

ID	Description
1= Fixed	All control devices are used to assist each other (run at the same time) and each device has its own setpoints. ('ON' P213, 223 & 'OFF' P214, 224).
3= Alternate	All control devices are used to assist each other (run at the same time). With each device having its own setpoints, ('ON' P213, 223 & 'OFF' P214, 224) but each time all devices have stopped, then the setpoints are sequentially rotated between the devices to ensure equal usage.

The **fourth parameter**, and **fifth parameter**, are set to determine the switch points, "ON" and "OFF" for the relay. See **control function**, table (**P211, 221, 231**) for further information.

P213, P223 - Relay Setpoint 1

This parameter determines the "ON" point for the control relay.

Relay Setpoints are entered in values of Measurement Units (P104).

P214, P224 - Relay Setpoint 2

This parameter determines the "OFF" point for the control relay.

Relay Setpoints are entered in values of Measurement Units (P104).

Common Parameters

P217, P227 - Relay Closures

The blackbox will record how many times each relay is closed, this parameter displays the number of times the relay has activated since the relay has been in use. It can be reset with any value.

P218, P228 - Relay Fail Safe

Your blackbox has a general fail-safe parameter **P808**. However, this can be overridden so that each individual relay has its own independent fail safe mode.

This parameter determines what the relay will do in the event of the **Fail safe Time (P809)** expiring.

Option	Description
0 = Default	Relay assumes system default mode P808
1 = Hold	Relay remains in its current state
2 = De-Energise	Relay will De-Energise
3 = Energise	Relay will Energise

Data Log Parameters

The data log parameters contains the following information.

Temperature

The following parameters give information on temperature conditions seen by the **Temperature source (P852)** in °C. All of these parameters are read only and cannot be changed, though if P852 is changed they will be reset.

P580 Minimum Temperature

This parameter displays the minimum temperature recorded.

P581 Minimum Temperature Date

This parameter displays the date when the minimum temperature was recorded.

P582 Minimum Temperature Time

This parameter displays the time when the minimum temperature was recorded.

P583 Maximum Temperature

This parameter displays the maximum temperature recorded.

P584 Maximum Temperature Date

This parameter displays the date when the maximum temperature was recorded.

P585 Maximum Temperature Time

This parameter displays the time when the maximum temperature was recorded.

P586 Current Temperature

This parameter displays the current temperature.

Display Parameters

Options

P801 Decimal Places

This parameter determines the number of decimal places shown on the display of the PC Programming Software (standard) or the Hand Held Calibrator (optional) when connected whilst the **blackbox** is in the run mode.

Minimum = 0 (No decimal places), Maximum 3 = (3 decimal Places)

Default = 2 (2 decimal Places)

Failsafe

P808 Fail-safe Mode

By default, if a fail-safe condition occurs, then the display and the output are held at their last **known** values until a valid reading is obtained.

If required, then you can change this so that the unit goes to **high** (100% of span), or **low** (empty) as follows:

Option	Description
1 = Known (Default)	Remain at the last known value
2 = High	Will fail to the high value (100% of Span).
3 = Low	Will fail to the low value (empty)

■ See Also P840 Output Fail-safe

Important Information

In the event of a **fail-safe** condition occurring, the display, (when connected to the PC Handheld Communicator or the optional Handheld Communicator) and Output can be configured to fail to a condition which is independent of each other. To set independent **Output Failsafe** see **P840**.

P809 Fail-safe Time

In the event of a fail-safe condition the fail safe timer determines the time before fail-safe mode is activated. **Default = 1min.**

If the timer activates, the unit goes into **fail-safe**, as determined by **P808,(Display)** and **P840 (Output)**. When this happens, when connected to the PC Handheld Communicator or the optional Handheld Communicator, you will see the message “**Failed Safe!**” on the display, along with a message explaining why (lost echo or transducer fault, for example)

When a valid measurement is obtained then the display and output will be restored and the timer is reset.

Output Parameters

Range

P830 Output Range

This parameter determines the range of the mA output, from the following.

Option	Description
0= Off	mA output disabled.
1= 0 to 20 mA	mA output directly proportional to the output mode (P831) , so if the reading is 0% the output is 0 mA. If the reading is 100% the output is 20 mA.
2= 4 to 20 mA (Default)	mA output directly proportional to the output mode (P831) , so if the reading is 0% the output is 4 mA. If the reading is 100% the output is 20 mA.
3= 20 to 0 mA	mA output inversely proportional to the output mode (P831) , so if the reading is 0% the output is 20 mA. If the reading is 100% the output is 0 mA.
4= 20 to 4 mA	mA output inversely proportional to the output mode (P831) , so if the reading is 0% the output is 20 mA. If the reading is 100% the output is 4 mA.

Operation

P831 Output Mode

This parameter determines how the mA Output relates to what is measured. By **default** it operates exactly the same as the display (**P100**), but it can be set to operate as follows:

Option	Description
0 = Default	mA output relative to Mode P100
1 = Distance	mA output relative to distance .
2 = Level	mA output relative to level .
3 = Space	mA output is relative to space .

Setpoint

By **default** the mA Output will represent the **empty (0 or 4mA)** dependant on (**P830**) **Output Range**) and **100%** of the operational **span (20mA)**, but you may wish to have the output represent a section of the operational span. For example, the application has an operational span of 6 metres but **output** is to **represent empty (0 or 4mA)** dependant on (**P830**) **Output Range**) to a **level of 5 metres (20mA)**. If so P834 (Low Level) should be set to 0.00 metres and P835 (High Level) should be set to 5 metres.

P834 Output Low Level

This parameter sets the level, distance or space, depending on the selected **Output Mode (P831)** at which the low mA output will occur (**0 or 4mA** dependant on (**P830**) **Output Range**)

Default = 0.000m

P835 Output High Level

This parameter sets the level, distance or space, depending on the selected **Output Mode (P831)** at which the high mA output will occur (**20mA**).

Default = 5.700m

Limits

P836 Output Low Limit

This parameter sets the lowest level that the mA output will drop to, the default is 0mA, but you can override this if the device you connect to cannot for example accept less than 2mA, yet you want to use the 0-20mA range.

Default = 0.00mA

P837 Output High Limit

This parameter sets the highest level that the mA output will rise to, the default is 20 mA, but you can override this if the device you connect to cannot for example accept more than 18 mA, yet you want to use the 0-20 mA range. **Default = 20.00mA**

Trim

P838 Output Low Trim

If the device you are connected to is not calibrated, and not showing the low value, then you can trim it using this parameter. You can either type in the offset directly, or use the arrow keys to move the output up and down until you get the expected result on the device that is connected.

P839 Output High Trim

If the device you are connected to is not calibrated, and not showing the high value, then you can trim it using this parameter. You can either type in the offset directly, or use the arrow keys to move the output up and down until you get the expected result on the device that is connected.

Failsafe

P840 Output Fail-safe Mode

This parameter determines what happens to the output in the event of the unit going into fail-safe mode. The **default** is to do the same as the **system fail-safe (P808)**, but this can be overridden to force the output to an independent fail-safe mode as follows:

Option	Description
0 = Default	output will fail as per P808 .
1 = Hold	output will retain its last known value.
2 = Low	output will fail to its low condition.
3 = High	output will fail to its high condition (20mA maximum).
4 = Very high	output will fail to its highest or fault condition of greater than 20mA (22mA maximum).

Compensation Parameters

Offset

P851 Measurement Offset

The value of this parameter is added to the measured distance, in **Measurement Units (P104)**.

This Offset will be added to the level, as derived from the transducer, and will affect everything including the reading on the display, when connected to the PC Handheld Communicator or the optional Handheld Communicator, relay setpoints and the output.

Temperature

P852 Temperature Source

This parameter determines the source of the temperature measurement. By **default** it is set to automatic (**P852=1**), which will automatically detect if a temperature sensor is available from the transducer. If for any reason, no temperature input is received, then the **Fixed Temp** value is used, as set by **P854**.

The temperature source can be specifically set as follows:

Option	Description
1 = Automatic (Default)	Will automatically select transducer temperature sensor, if available, or fixed temperature (P854) if no temperature sensor found.
2 = Fixed	Always uses fixed temperature (P854)

P854 Fixed Temperature

This parameter sets the temperature, in degrees centigrade to be used if **P852 (Temperature Source) =2**. Default = 20°C

Stability Parameters

Damping

Damping is used to damp the display, to enable it to keep up with the process but ignore minor surface fluctuations.

P870 Fill Damping

This parameter determines the maximum rate at which the unit will respond to an increase in level. It should be set slightly higher than the maximum vessel fill rate. **Default = 10.000 metres/minute**

P871 Empty Damping

This parameter determines the maximum rate at which the unit will respond to a decrease in level. It should be set slightly higher than the maximum vessel empty rate. **Default = 10.000 metres/minute**

Filters

The following two parameters can be used to filter out unwanted changes of level caused by a ‘rippled’ or agitated surface.

P881 Fixed Distance

This parameter determines the width of gate to be used in tracking an echo and under normal circumstances will not require changing, but it can be increased in the cases where the surface is moving extremely fast (in excess of 10m/min) to ensure smooth processing of the changing level.

P882 Process Filter

This parameter determines the number of ‘cycles’ that will be taken before a change in level is processed and the display updated.

Option	Description
1 = Fast	level will be updated every cycle
2 = Medium	level will be updated every 8 cycles
3 = Slow (Default)	level will be updated every 16 cycles

Echo Processing Parameters

Transducer Status

P900 Transducer Status

This parameter shows the current state of the transducer. The value means the following.

Option	Description
0= OK (Default)	Transducer working correctly.
1= Disabled	Transducer is not being used
2= Stuck High	Indicates that the power and signal lines on the transducer terminals are crossed over, or the signal line is shorted to earth.
3= Not Found	No transducer is detected.

P901 Echo Confidence

This parameter shows the most recent echo confidence from the transducer. It is useful to help find the best mounting location for the transducer, where you should aim to get the highest figure. It is a percentage of confidence that the echo reporting the level is the correct one.

P902 Echo Strength

This parameter shows the most recent echo strength figure for the transducer, where a higher figure indicates a better returned echo.

P903 Average Noise

This is the mean noise reading for the transducer. It is measured while the transducer is not firing, and gives an indication of the average amount of electrical noise present on the cabling.

P904 Peak Noise

This is the peak noise reading for the transducer. It is measured while the transducer is not firing, and gives an indication of the maximum amount of electrical noise present on the cabling.

System Parameters

Passcode

P921 Enable Code

Enables the passcode (**P922**), which means the passcode must be entered to go into program mode. If **disabled** (set to **0**), then no passcode is required, and **ENTER** is used to enter program mode. **Default = 1 (Enabled)**

P922 Passcode

This is the passcode that must be used to enter program mode. The **default** is **1997**, but this can be changed to another value from 0 to 9999.

System Information

The following three parameters do not affect how the unit performs, but details, contained in them, may be required, by Pulsar, when making technical enquiries.

P926 Software Revision

This parameter will show the current software revision.

P927 Hardware Revision

This parameter will show details of the current hardware revision.

P928 Serial Number

This parameter will show the serial number of the unit.

P929 Site Identification

This parameter allows you to give each unit an individual reference number, for identification purposes. You can set any number between 1 and 99999.

P930 Factory Defaults

This parameter resets all parameter values to the original Factory Set values that were installed when the unit was tested, before despatch to you.

To **reset** parameters, enter **1 (Yes)**, and press **ENTER**, then you will see a message "**Entr if sure**", you should press **ENTER** again. If you press any other key at this point, the parameters will not be reset, and you will see a message confirming this.

Once you have done this, program the unit, to the desired application.

Date & Time

P931 Date

This parameter shows the **current date**, in the format as set by **P933 (Date Format)**, and can be reset if required.

P932 Time

This parameter shows the **current time** and can be reset if required, in the format HH: MM (24-hour format). This is set initially at the factory for UK time.

P933 Date Format

This parameter allows you to alter the format that the date is displayed to your choice of DD: MM: YY, MM: DD: YY or YY: MM: DD. The default is DD: MM: YY.

Daylight Saving Time

Important Information

In order to ensure the correct operation of Daylight Saving Time **P932 Time** should be checked, and adjusted if necessary, to ensure that it is set for the current valid time.

P970 DST Enable

When **Enabled** (set to **1**) the internal clock will be automatically adjusted to compensate for the difference between standard time and **Daylight Saving Time**. **Default = 0 (Off)**

P971 DST Difference

This parameter sets the time difference between standard time and **Daylight Saving Time**. The time difference is entered in HH:MM. **Default = 01:00**

P972 DST Start Time

This parameter is used to set the **time** of day at which **Daylight Saving Time** will **start**, the time is entered in the format HH: MM (24-hour format). **Default = 02:00**

P973 Start Day

Use this parameter to enter the **day** of the week (**P974**) that **Daylight Saving Time** is to **start**.

Option	Description
2= Monday	DST will start on a Monday
3= Tuesday	DST will start on a Tuesday
4= Wednesday	DST will start on a Wednesday
5= Thursday	DST will start on a Thursday
6= Friday	DST will start on a Friday
7= Saturday	DST will start on a Saturday
8= Sunday (Default)	DST will start on a Sunday

P974 Start Week

This parameter will determine the **week** of the month (**P975**) in which **Daylight Saving Time** is to **start**.

Option	Description
1= Week 1	DST will start on day (P973) in the first week (P974) of the month (P975).
2= Week 2	DST will start on day (P973) in the second week (P974) of the month (P975).
3= Week 3	DST will start on day (P973) in the third week (P974) of the month (P975).
4= Week 4	DST will start on day (P973) in the fourth week (P974) of the month (P975).
5= Last (Default)	DST will start on day (P973) in the last week (P974) of the month (P975).

P975 Start Month

This parameter is used to select the **month**, in which **Daylight Saving Time** will **start**.

Option	Description
1= January	DST will start during the month of January
2= February	DST will start during the month of February
3= March (Default)	DST will start during the month of March
4= April	DST will start during the month of April
5= May	DST will start during the month of May
6= June	DST will start during the month of June
7= July	DST will start during the month of July
8= August	DST will start during the month of August
9= September	DST will start during the month of September
10= October	DST will start during the month of October
11= November	DST will start during the month of November
12= December	DST will start during the month of December

P976 DST End Time

This parameter is used to set the **time** of day at which **Daylight Saving Time** will **end**, the time is entered in the format HH: MM (24-hour format).
Default = 02:00

P977 End Day

Use this parameter to enter the **day** of the week (**P974**) that **Daylight Saving Time** is to **end**.

Option	Description
2= Monday	DST will end on a Monday
3= Tuesday	DST will end on a Tuesday
4= Wednesday	DST will end on a Wednesday
5= Thursday	DST will end on a Thursday
6= Friday	DST will end on a Friday
7= Saturday	DST will end on a Saturday
8= Sunday (Default)	DST will end on a Sunday

P978 End Week

This parameter will determine the **week** of the month (**P975**) in which **Daylight Saving Time** is to **end**.

Option	Description
1= Week 1	DST will end on day (P977) in the first week (P978) of the month (P979).
2= Week 2	DST will end on day (P977) in the second week (P978) of the month (P979).
3= Week 3	DST will end on day (P977) in the third week (P978) of the month (P979).
4= Week 4	DST will end on day (P977) in the fourth week (P978) of the month (P979).
5= Last (Default)	DST will end on day (P977) in the last week (P978) of the month (P979).

P979 End Month

This parameter is used to select the **month**, in which **Daylight Saving Time** will **end**.

Option	Description
1= January	DST will end during the month of January
2= February	DST will end during the month of February
3= March	DST will end during the month of March
4= April	DST will end during the month of April
5= May	DST will end during the month of May
6= June	DST will end during the month of June
7= July	DST will end during the month of July
8= August	DST will end during the month of August
9= September	DST will end during the month of September
10= October (Default)	DST will end during the month of October
11= November	DST will end during the month of November
12= December	DST will end during the month of December

Test Parameters

Simulation

P980 Simulate

Test mode is used to simulate the application and confirm that all parameters and relay setpoints have been entered as expected. During simulation, there is a choice of whether the relays will change state (hard simulation) or not (soft simulation), but the LED's will always switch according to how the relays have been programmed, and the output will change accordingly. If you want to test the logic of the system that the relays are connected to then select a hard simulation, but if you don't want to change the relay state, then select a soft simulation.

There are two simulation modes, **automatic** and **manual**. Automatic simulation will move the level up and down between empty and full level and activate the relay and/or corresponding LED at the switchpoints programmed, if you wish to change the direction of the level movement at anytime this can be done by using the arrow keys. In manual simulation, using the arrow keys will allow you to move the level up and down as required.

The choices for you to enter are as follows.

- 1= Manual soft simulation
- 2= Automatic soft simulation
- 3= Manual hard simulation
- 4= Automatic hard simulation

To return to program mode, press **CANCEL** and test mode will end.

P981 Increment

By default, simulation mode will move by **0.25m** steps in manual simulation and by 0.25m/min in automatic simulation. Altering the increment can change this value.

P982 Rate

In automatic mode, the rate at which the level will move up and down is determined by distance, **P981 Increment** and the time, **P982 Rate** which can be changed as required. To increase the rate at which the level moves increase the **Increment (P981)** or decrease the **Rate (P982)**. To decrease the rate at which the level moves decrease the **Increment (P981)** or increase the **Rate (P982)**.

Hardware

P992 Output Test

This parameter will allow you to force a specified current on to the output to test any equipment that it is connected to. The figure you enter will be generated by the output.

P993 Relay Test

Press a numeric key corresponding to the number of the relay you wish to test, and the relay will change state each time the key is pressed. If you press any other key, other than a valid relay number, then the test will end.

P994 Transducer Test

Press any key on the keypad, other than 0, and the transducer will continually fire for 5 seconds, pressing 0 will terminate the test.

Chapter 6 Troubleshooting

This section describes many common symptoms, with suggestions as to what to do.

Symptom	What to Do
No reading being obtained, transducer not firing.	Check power supply. Check wiring to transducer.
Incorrect reading being obtained for current level.	Measure actual distance from transducer head to surface of material. Enter Program Mode and directly access P21 (Set Distance) type in the measured distance, press ENTER, when prompted press ENTER again, wait until SET displayed. Return to Run Mode, display should now update to correct reading.
Material level is consistently incorrect by the same amount.	Check empty level (P105), display offset (P802), and measurement offset (P851).
LED's change colour at relevant relay switch points but relays do not change state.	Check supply to unit and ensure voltage selector set to correct position.

Parameter Record

APPLICATION

Operation

Parameter Details		Entered Values					
No.	Description	Default	1	2	3	4	5
P100	Mode	1 = Dist.					
P101	Xducer	2 = dB6					

Distances

Parameter Details		Entered Values					
No.	Description	Default	1	2	3	4	5
P104	Measurement Units	1=metres					
P105	Empty Level	6.000 metres					
P106	Span	5.700 metres					
P107	Near Blanking	0.300 metres					
P108	Far Blanking	20.0%					

Remote Alarm

Parameter Details		Entered Values					
No.	Description	Default	1	2	3	4	5
P985	Tel. No. 1	1 = Add 0					
P986	Tel. No. 2	0					
P987	Tel. No. 2	0					
P988	Call Type	0 = Off					

SMS Time

Parameter Details		Entered Values					
No.	Description	Default	1	2	3	4	5
P995	Interval	0.00 mins.					
P996	SMS Start	00:00					
P997	SMS Stop	23:59					
P998	SMS Days	0					

RELAYS

Relay 1

Parameter Details		Entered Values					
No.	Description	Default	1	2	3	4	5
P210	R1 Type	0 = Off					
P211	R1 Function	0 = Off					
P212	R1 Alarm ID/Pump	1 = Off					
P213	R1 Set 1	0.000 metres					
P214	R1 Set 2	0.000 metres					
P217	R1 Closures	0					
P218	R1 Fail Safe	0					

Relay 2

Parameter Details		Entered Values					
No.	Description	Default	1	2	3	4	5
P220	R2 Type	0 = Off					
P221	R2 Function	0 = Off					
P222	R2 Alarm ID/Pump	1 = Off					
P223	R2 Set 1	0.000 metres					
P224	R2 Set 2	0.000 metres					
P227	R2 Closures	0					
P228	R2 Fail Safe	0					

DATA LOGS

Temperature

Parameter Details		Entered Values					
No.	Description	Default	1	2	3	4	5
P580	Minimum Temperature	Read Only					
P581	Min Temperature Date	Read Only					
P582	Min Temperature Time	Read Only					
P583	Maximum Temperature	Read Only					
P584	Max Temperature Date	Read Only					
P585	Max Temperature Time	Read Only					
P586	Current Temperature	Read Only					

DISPLAY

Options

Parameter Details		Entered Values					
No.	Description	Default	1	2	3	4	5
P801	Decimal Places	2					

Fail Safe

Parameter Details		Entered Values					
No.	Description	Default	1	2	3	4	5
P808	Fail Mode	1 = Known					
P809	Fail Time	2.0 mins					

OUTPUT

Range

Parameter Details		Entered Values					
No.	Description	Default	1	2	3	4	5
P830	Output Range	2 = 4 – 20mA					

Operation

Parameter Details		Entered Values					
No.	Description	Default	1	2	3	4	5
P831	Output Mode	0 = Default					

Set Point

Parameter Details		Entered Values					
No.	Description	Default	1	2	3	4	5
P834	Low Level	0.000 metres					
P835	High Level	6.000 metres					

Limits

Parameter Details		Entered Values					
No.	Description	Default	1	2	3	4	5
P836	Low Limit	0.00 mA					
P837	High Limit	20.00 mA					

Trim

Parameter Details		Entered Values					
No.	Description	Default	1	2	3	4	5
P838	Low Trim	0.00					
P839	High Trim	0.00					

Fail Safe

Parameter Details		Entered Values					
No.	Description	Default	1	2	3	4	5
P840	Fail Mode	0 = Default					

COMPENSATION

Offset

Parameter Details		Entered Values					
No.	Description	Default	1	2	3	4	5
P851	Measurement Offset	0.000 metres					

Temperature

Parameter Details		Entered Values					
No.	Description	Default	1	2	3	4	5
P852	Temperature Source	1 = Automatic					
P854	Fixed Temperature	20.00 Deg. C					

STABILITY

Damping

Parameter Details		Entered Values					
No.	Description	Default	1	2	3	4	5
P870	Fill Damping	10.000					
P871	Empty Damping	10.000					

Filters

Parameter Details		Entered Values					
No.	Description	Default	1	2	3	4	5
P881	Fixed Dist.	0.20m					
P882	Process Filter	3 = Slow					

ECHO PROCESS

Xducer Status

Parameter Details		Entered Values					
No.	Description	Default	1	2	3	4	5
P900	Xducer Status	Read Only					
P901	Echo Confidence	Read Only					
P902	Echo Strength	Read Only					
P903	Average Noise	Read Only					
P904	Peak Noise	Read Only					

SYSTEM

Passcode

Parameter Details		Entered Values					
No.	Description	Default	1	2	3	4	5
P921	Enable Code	1 = Yes					
P922	Passcode	1997					

System Information

Parameter Details		Entered Values					
No.	Description	Default	1	2	3	4	5
P926	Software Revision	Read Only					
P927	Hardware Revision	Read Only					
P928	Serial Number	Read Only					
P929	Site Ident.	1					

Date & Time

Parameter Details		Entered Values					
No.	Description	Default	1	2	3	4	5
P931	Date	Current Date					
P932	Time	Current Time					
P933	Date Format	1=DD:MM:Y					

Daylight Save

Parameter Details		Entered Values					
No.	Description	Default	1	2	3	4	5
P970	DST Enable	0					
P971	DST Differen	01:00					
P972	DST Start Time	02:00					
P973	Start Day	8					
P974	Start Week	1					
P975	Start Month	3					
P976	DST End Time	02:00					
P977	End Day	8					
P978	End Week	5					
P979	End Month	10					