

# IMP+

## INSTRUCTION MANUAL

---



---

# PULSAR

Process Measurement



## **IMP+ (THIRD EDITION)**

March 2009

Part Number M-080-0-003P

### **COPYRIGHT**

© Pulsar Process Measurement Limited, 2005-9. All rights reserved. No part of this publication may be reproduced, transmitted, transcribed, stored in a retrieval system, or translated into any language in any form without the written permission of Pulsar Process Measurement Limited.

### **WARRANTY AND LIABILITY**

Pulsar Process Measurement Limited guarantee for a period of 2 years from the date of delivery that it will either exchange or repair any part of this product returned to Pulsar Process Measurement Limited if it is found to be defective in material or workmanship, subject to the defect not being due to unfair wear and tear, misuse, modification or alteration, accident, misapplication or negligence.

### **DISCLAIMER**

Pulsar Process Measurement Limited gives nor implies any process guarantee for the this product, and shall have no liability in respect of any loss, injury or damage whatsoever arising out of the application or use of any product or circuit described herein.

Every effort has been made to ensure accuracy of this documentation, but Pulsar Process Measurement Limited cannot be held liable for any errors.

Pulsar Process Measurement Limited operates a policy of constant development and improvement and reserves the right to amend technical details as necessary.

### **TECHNICAL ENQUIRIES**

Please contact Pulsar Process Measurement Limited for technical support.

### **COMMENTS AND SUGGESTIONS**

If you have any comments or suggestions about this product, then please contact:

#### **Pulsar Process Measurement Limited**

Cardinal Building  
Enigma Commercial Centre  
Sandy's Road  
Malvern  
Worcestershire  
WR14 1JJ  
United Kingdom

Tel: + 44 (0) 870 6039112

Fax: + 44 (0) 870 6039114

Web Site: <http://www.pulsar-pm.com>

e-mail: [info@pulsar-pm.com](mailto:info@pulsar-pm.com) (general information)

e-mail: [support@pulsar-pm.com](mailto:support@pulsar-pm.com) (product support)

#### **Pulsar Process Measurement Inc.**

PO Box 5177  
Niceville  
FL 32578-5177  
USA

Tel: + 1 850 279 4882

Fax: + 1 850 279 4886

Web Site: <http://www.pulsar-pm.com>

e-mail: [info.usa@pulsar-us.com](mailto:info.usa@pulsar-us.com) (general information)

e-mail: [support.usa@pulsar-pm.com](mailto:support.usa@pulsar-pm.com) (product support)



# Contents

Chapter 1 Start Here .....	1
About this Manual .....	1
About the $\pm MP+$ Level Monitoring System .....	2
Functional Description .....	2
Product Specification .....	4
Physical .....	4
Environmental .....	4
Performance .....	4
Standard features .....	4
Additional features - 3wires .....	4
PC interface .....	4
Chapter 2 Installation .....	5
Power Supply Requirements .....	5
Terminal Connections .....	11
2 Wire .....	11
Loop Resistance .....	11
3 Wire .....	12
Preparation for Operation .....	12
Maintenance .....	13
Chapter 3 How To Use Your $\pm MP+$ Level Monitoring System .....	14
Operating the Controls .....	14
Display .....	14
Run Mode .....	14
Program Mode .....	15
Button Functions .....	15
How to Access Program Mode .....	16
Parameter Defaults .....	17
Factory Defaults .....	17
Chapter 4 Getting Results With Your $\pm MP+$ .....	18
Setting up Your Application .....	18
Empty Distance .....	18
Span .....	18
Near and Far Blanking .....	18
Using the 4-20 mA Output .....	18
Using the Relays .....	19
Alarm Relay Set-up .....	20
Control Relay Set-up .....	21
Loss of Echo Set-up .....	21
Other Relay Parameters .....	22
Setting Security Passcodes .....	22
Using A Passcode .....	22
Changing The Passcode .....	23
Resetting Factory Defaults .....	23
Checking the Information Specific to your $\pm MP+$ .....	23
Checking the Software Revision and Serial Number .....	23
Using the RS232 Serial Interface .....	23
Chapter 5 Parameter Guide .....	25
Parameter Listing .....	25
Application (APP) Menu .....	25

P100 Mode of Operation.....	25
P104 Measurement Units.....	25
P105 Empty Level.....	25
P106 Span.....	26
P107 Near Blanking Distance.....	26
P108 Far Blanking Distance.....	26
Relay (rL) Menu.....	27
P210 (Relay 1), P220 (Relay 2) - Relay Type.....	27
Alarms.....	27
P213 (Relay 1), P223 (Relay 2) - Relay "ON" Setpoint.....	28
P214 (Relay 1), P224 (Relay 2) - Relay "OFF" Setpoint.....	28
Control.....	28
P213 (Relay 1), P223 (Relay 2) - Relay "ON" Setpoint.....	29
P214 (Relay 1), P224 (Relay 2) - Relay "OFF" Setpoint.....	29
Volume (UoL) Menu.....	30
P600 Vessel Shape.....	30
P601-P603 Vessel Dimensions.....	32
P604 Calculated Volume.....	32
P605 Volume Units.....	33
P606 Correction Factor.....	33
P607 Max Volume.....	33
Display (DiSP) Menu.....	33
P800 Display Units.....	33
P801 Decimal Places.....	34
P808 Fail-safe Mode.....	34
P809 Fail-safe Time.....	34
mA Output (LOOP) Menu.....	34
P834 mA Low Level.....	34
P835 mA High Level.....	34
P838 mA Low Trim.....	35
P839 mA High Trim.....	35
P840 mA Fail-safe Mode.....	35
P842 Voltage Output.....	35
Compensation (CoP) Menu.....	36
P851 Measurement Offset.....	36
P852 Temperature Source.....	36
P854 Fixed Temperature.....	36
P860 Sound Velocity.....	36
P645 Vapour Temperature Compensation.....	37
Stability (StA) Menu.....	38
Damping.....	38
System (SyS1) Menu.....	38
P921 Enable Code.....	38
P922 Passcode.....	38
P926 Software Revision.....	38
P928 Serial Number.....	38
P930 Factory Defaults.....	39
Test (tESt) Menu.....	39
P991 Hard Test.....	39
P992 mA Out Test.....	39
Chapter 6 Troubleshooting.....	40
Parameter Record.....	41

Congratulations on your purchase of a Pulsar **±MP+** Level Monitoring System. This quality system has been developed over many years and represents the latest in high technology ultrasonic level measurement and control.

It has been designed to give you years of trouble-free performance, and a few minutes spent reading this operating manual will ensure that your installation is as simple as possible.

### **About this Manual**

It is important that this manual is referred to for correct installation and operation.

There are various parts of the manual that offer additional help or information as shown:

#### **Tips**



#### **TIP**

At various parts of this manual you will find tips to help you.

#### **Additional Information**

##### **Additional Information**

At various parts of the manual, you will find sections like this that explain specific items in more detail.

## About the **IMP+** Level Monitoring System



### **Functional Description**

The **IMP+** level monitoring system is a highly developed ultrasonic level measurement system which provides non-contacting level measurement for a wide variety of applications in both liquids and solids. Its unique design allows for both 3 wire and 2 wire (loop powered) configuration all with in the same unit.

Easy calibration and maintenance free “fit and forget” performance mean that you can install the **IMP+** Level Monitoring System rapidly and with confidence. Two relays which can be configured for either alarm or control functions, with fully programmable setpoints are provided when connected as a 3 wire device, together with fault condition being indicated by the mA output on both the 2 and 3 wire mode.

The **IMP+** operates on the principle of timing the echo received from a measured pulse of sound transmitted in air and utilises “state of the art” echo extraction technology.

**IMP+** comes in three models: IMP 3 with a range from 0.20m (0.66 feet) to 3.00m (9.84 feet), IMP 6 with a range of 0.3m (0.98 feet) to 6.00m (19.69 feet) and IMP 10 with a range of 0.3m (0.98 feet) to 10.00m (32.81 feet).

The **IMP+** can show **level, space, distance**, on the display. The relays can be programmed to give an 'ON' and 'OFF' point for external control. There is a 4-20 mA output (non isolated in 3 wire mode) that can be connected to a remote chart recorder or PLC, to monitor level, space or distance, dependant on the measurement mode selected, and provides a 'fault condition' alarm of either 3.5mA or 22mA.

The **IMP+** has an IP65 lid covering an integral LCD display and 4 buttons which are used for programming purposes when in Program Mode and as hot keys providing additional information whilst in Run Mode.

## **Product Specification**

### **Physical**

- Dimensions 186mm (5.24 inches) O/A height x 133mm (7.32 inches) O/A diameter.
- Cable entry 2 off cable glands 4.5 -10mm. (Torque to 2NM)
- Mounting 1.5" BSP/NPT (IMP3 and 6 models) 2" BSP/NPT (IMP 10)
- Weight approx 1KG

### **Environmental**

- Temperature range -40 to +65°C. Ambient
- Temperature range -40 to +80°C. Transducer
- IP rating IP67

### **Performance**

- Digital processing of echo
- Input Voltage range 11-30volts DC. Current output 3.5-22mA.
- Measurement range 200mm (0.66 feet) to 1000mm (32.81 feet), (dependant on model) accuracy  $\pm 0.25\%$  or 6mm which ever is greatest.
- 4-20mA output resolution 5 $\mu$ A.  
**2 wire configuration isolated**  
**3 wire configuration non isolated**
- Temperature compensation via internal digital temperature sensor with  $\pm 0.5^\circ\text{C}$  accuracy.
- Current consumption for 3 wire mode max 60 ma
- Time from power up to stable reading 10 seconds.

### **Standard features**

- RS232 connection for diagnostics and software updates
- 4 Digit LCD display
- 4 button keypad for parameter entry

### **Additional features - 3wires.**

- Backlight fitted to LCD display
- 0-10v analogue output
- 2 off SPDT relays rated 1A 30VDC/AC

### **PC interface**

- All parameters can be accessed and changed via IMP view software.
- Trace viewing ability.

### Power Supply Requirements

The **IMP+** operates from a DC supply of 11 –30V and will typically draw less than 0.06A.

*All electronic products are susceptible to electrostatic shock, so follow proper grounding procedures during installation.*

The compact one-piece construction of the **IMP+** can be mounted easily using the integral nose thread (1.5" or 2" BSP/ NPT, dependent on model).

When choosing a location to mount the Imp, bear in mind the following:

- For access to the LCD display and programming buttons it is recommended that you mount it in an area which is easily accessible.
- The ultrasonic signal path should be free of falling material and obstructions such as pipes, beams etc.
- The IMP 3 should be mounted at least 20cm (0.66 feet) above the maximum level of the material and be perpendicular to the surface. Whilst the IMP 6 and 10 should be mounted at least 30cm (0.98 feet) above the maximum level of the material and be perpendicular to the surface.
- The ambient temperature is between -20°C and 65°C.
- There should be no high voltage cables or electrical inverters close by.

## Dimensions

The dimensions of the **IMP+** are as shown below.

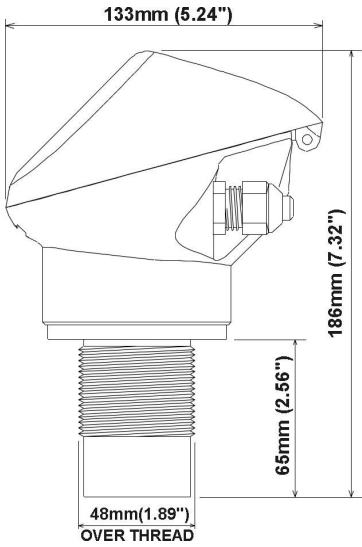

1.5" BSP/NPT – IMP 3 & 6

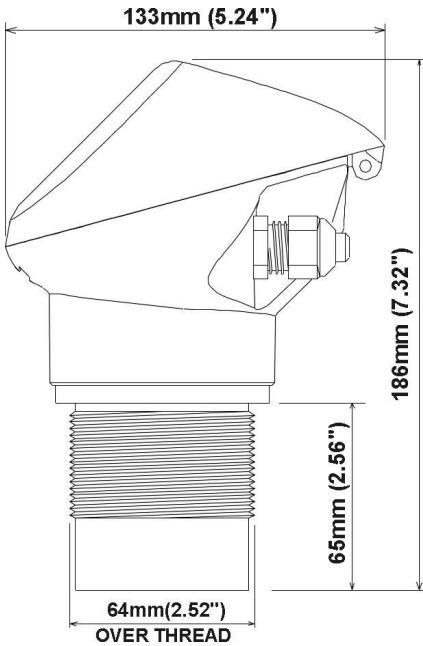
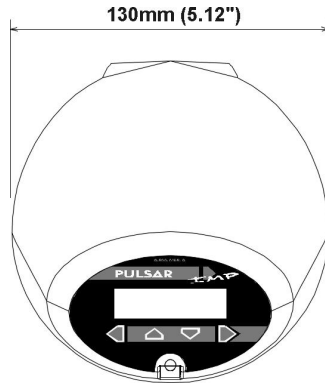

2" BSP/NPT – IMP 10

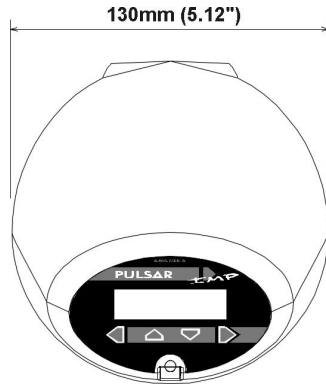

**Outdoor and Open Vessel Installation**

The **IMP+** can be simply mounted on a bracket, suitable for the application and secured using the thread located at the top of the transducer (2" BSP/NPT).

Care should be taken to ensure that the **IMP+** is not installed in direct sunlight, in order to avoid errors in the measurement of ambient temperature.

Attention should also be taken, when mounting the unit, to ensure that strong windy conditions are avoided, wherever possible, to prevent abnormal operation.

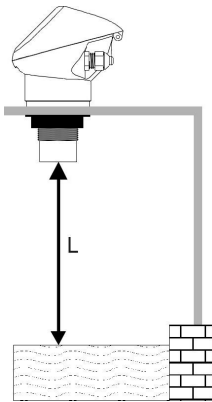

<b>IMP+ Model</b>	<b>Range</b>	<b>L = Blanking</b>
<b>Imp 3</b>	<b>3 metres (9.84 feet)</b>	<b>200mm (0.66 feet)</b>
<b>Imp 6</b>	<b>6 metres (19.69 feet)</b>	<b>300mm (0.98 feet)</b>
<b>Imp 10</b>	<b>10 metres (32.18 feet)</b>	<b>300mm (0.98 feet)</b>

**“L” should as a minimum be at least that as detailed in the table above, but can be greater if required.**

**Closed Vessel Installation**

“L” should as a minimum be at least that as detailed in the table above, but can be greater if required. The **IMP+** can be simply screwed into a flange and secured using the thread located at the top of the transducer (1.5" or 2" BSP/NPT, dependent on model).

Where possible use a flange made of a synthetic material such as PVC, in cases where a metal flange is used it is advisable to fit a suitable gasket between the flange of the **IMP+** and the connection to the vessel.

## Stand Pipe Installations

When mounting the **TMP+** to a standpipe care should be taken to ensure that the standpipe is of sufficient diameter with reference to its length, see the table below for details:

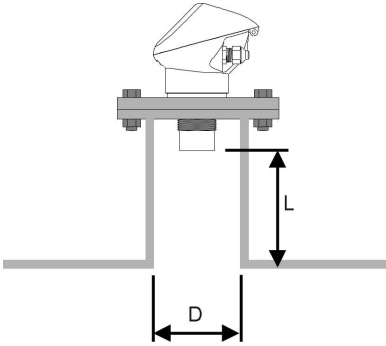

Dia. (D)		Max. Length (L)	
mm	inches	mm	inches
80	3	220	8
100	4	300	12
150	6	420	16
200	8	560	22

When using a standpipe, fixed to the top of a vessel, ensure that the open end of the standpipe is clear of any obstructions such as weld seams, gaskets etc. in order to avoid unwanted signal returns.

If using standpipes which extend in to the vessel, beyond the blanking distance, but not as far as the empty level, then the open end of the standpipe should be cut to an angle of 45°.

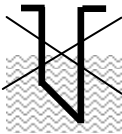

The maximum level (100% of Span) is inside the Blanking Distance

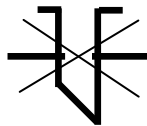

Pipe should be free of obstructions such as weld seams



Correct standpipe installation

## Cable Entry

The **IMP+** Series has two M16 cable entries, fitted with a suitable gland, to ensure moisture protection is maintained.

## Terminal Connection Details

The **IMP+**'s unique design allows for both 3 wire and 2 wire (loop powered) configuration within the same unit the terminal connections for both configurations are as detailed below. Wiring details are also given on the terminals under the access cover.

### **2 Wire (loop powered)**

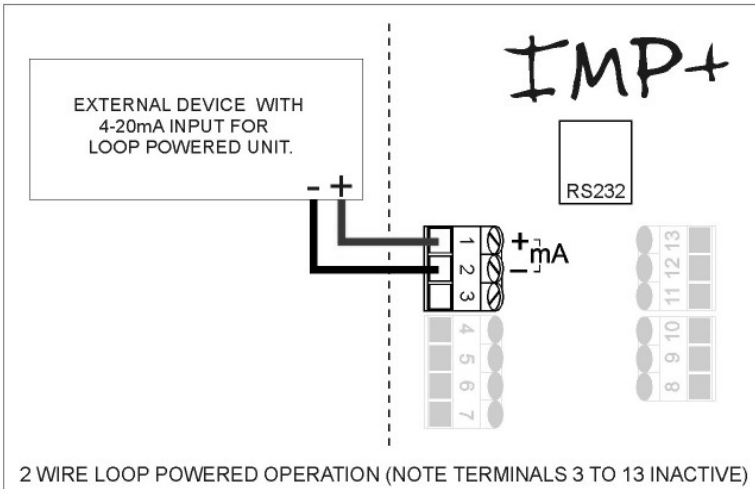

### 3 Wire

Source mode - the **power** for the **loop** is **supplied** by the **IMP+**

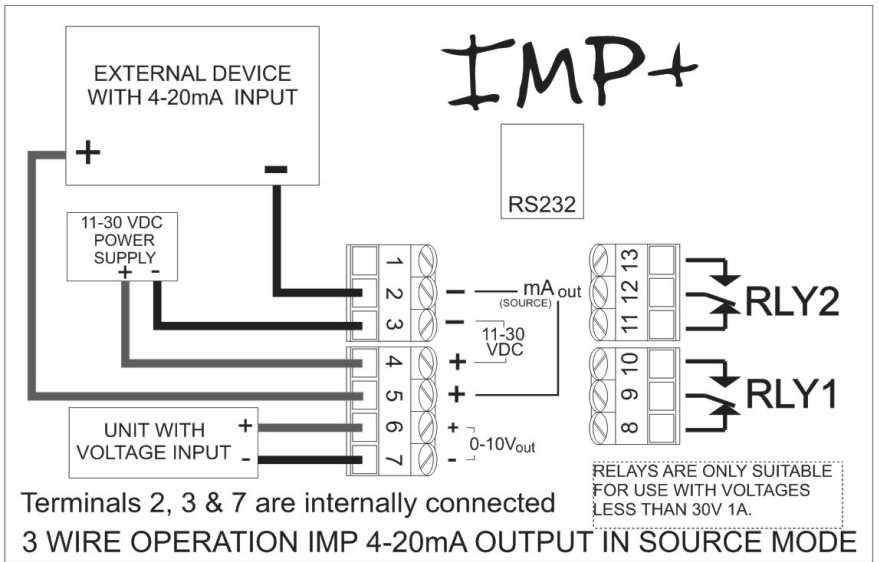

## Terminal Connections

### 2 Wire

Terminal 1 + ve: Direct Current (DC) input (11-30VDC)

Terminal 2 - ve: Current Output (4-20mA)

### Loop Resistance

For two wire operation the maximum cable resistance allowable can be calculated from the graph below. For example if an **IMP+** were supplied from 24v connected as a 2 wire unit (4-20mA only), the maximum total cable resistance is 590 ohms, for a typical 77 ohm /km cable this would mean a maximum cable length of  $590/77 = 7.6\text{km}$ , remember this total cable resistance, so this figure has to be divided by 2 to give 3.8km max distance.

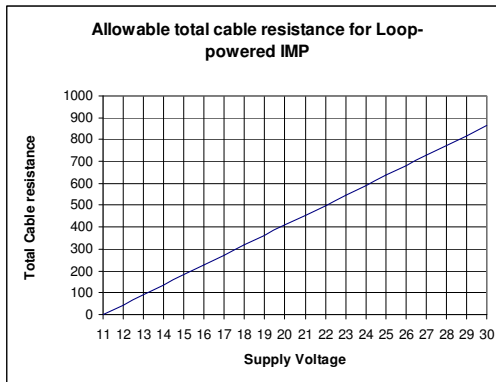

**Maximum cable resistance vs supply voltage for 2 wire mode.**

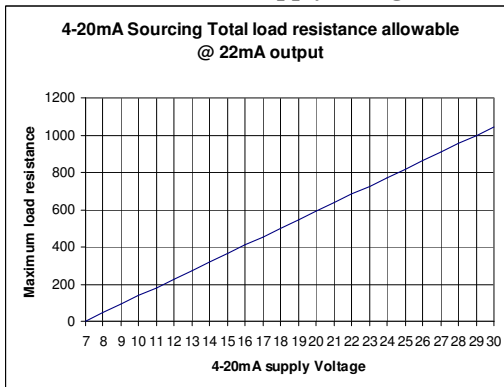

**Maximum cable resistance vs supply voltage for 3 wire mode.**

### **3 Wire**

- Terminal 1 + ve Current Output (4 – 20mA SINK MODE)  
(NOT USED IN SOURCE MODE)
- Terminal 2 - ve ground (4-20mA SINK MODE)
- Terminal 3 - ve: Direct Current (DC) input (11-30VDC)
- Terminal 4 + ve: Direct Current (DC) input (11-30VDC)
- Terminal 5 + ve Current Output (4 – 20mA SOURCE MODE)
- Terminal 6 + ve: 0-10V output (P842 = 1) or 0-5V output (P842 = 0)
- Terminal 7 - ve: 0-10V output (P842 = 1) or 0-5V output (P842 = 0)
- Terminal 8 Relay 1 Normally Open (N/C) Contact (De-energised)
- Terminal 9 Relay 1 Common
- Terminal 10 Relay 1 Normally Closed (N/O) Contact (De-energised)
- Terminal 11 Relay 2 Normally Open (N/C) Contact (De-energised)
- Terminal 12 Relay 2 Common
- Terminal 13 Relay 2 Normally Closed (N/O) Contact (De-energised)

#### **Important Information**

If the equipment is installed or used in a manner not specified in this manual, then the protection provided by the equipment may be impaired.

### **Preparation for Operation**

Before switching on, check the following:

- ✓ The **IMP+** is mounted correctly.
- ✓ The power supply is correctly installed.

## **Maintenance**

There is no user serviceable parts inside your **IMP+**, if you experience any problems with the unit, then please contact Pulsar Process Measurement for advice.

To clean the equipment, wipe with a damp cloth. Do not use any solvents on the enclosure.

### Operating the Controls

#### Display

Whilst in the Run Mode, the 4 digit LCD, by default, will display the current level reading in metres, the display will also alternate between the reading and “LOE” when a fault condition (Loss Of Echo) is detected. When in the Program Mode the display is used to read information on the Menu Options and the values entered.



There are two operating modes for your  $\pm$ IMP+, **Run Mode** and **Program Mode**.

#### Run Mode

This mode is used once the  $\pm$ IMP+ has been set up in program mode. It is also the default mode that the unit reverts to when it resumes operation after a power failure.

When the  $\pm$ IMP+ is switched on for the first time, it will display, in metres, the distance from the transducer face to the target.

After programming is complete, any relay outputs that are set will operate when the level reaches the relevant setpoint.

## **Program Mode**

This mode is used to set up the **IMP+** or change information already set, this is achieved by using the 4 push buttons located below the display.

Entering a value for each of the menu options that are relevant to your application provides all the programming information.

## **Button Functions**

There are 4 push buttons located under the display. Their name and functions are as follows:

<b>Button</b>	<b>Run Mode</b>	<b>Program Mode</b>
<b>ESC</b> ←	Displays details of unit Serial No. and Software Version	Used to Navigate out of the Menu System and return to Run Mode. Also used to Cancel a Parameter Value entered in error.
<b>UP</b> ▲	Displays Current Temperature	Used for Navigating around Menu Sytem and Increasing Menu Option Values.
<b>DOWN</b> ▼	Displays Current Echo Strength (dB's)	Used for Navigating around Menu Sytem and Decreasing Menu Option Values.
<b>ENTER</b> ▶	Displays current mA output	Used to confirm an action such as entering a Menu Option or Enter a Parameter Value.

## How to Access Program Mode

To access the **Program mode** press the “**ESC**” and “**Enter**” button simultaneously, where upon the display will show **PASS** on the LCD display briefly, to prompt you to enter the password, the display will now show **0000**, and the left hand digit will flash.

By using the UP and DOWN keys to increment or decrement the digit, and the ENTER key to shift the flashing digit to the next position. Assuming the passcode is the default 1997, then you should enter this.

**1 9 9 7**

The ESC key can be used to go back to the previous digit. Finally when you have selected all digits pressing the ENTER key again will input the selected pass code to the **IMP+**; if successful the display will show APP (Application). If however you input the wrong pass code the **IMP+** LCD display will show Fail for 2 seconds and will revert back to run mode.

### Using The Menu System

The menu system has been designed to make the changing of parameters very simple. Once in the **Program Mode** the display will show a line of text that displays the menu system. Pressing the **Up** and **Down** buttons will scrolls the display between the menu items, (as shown below, starting at APP).

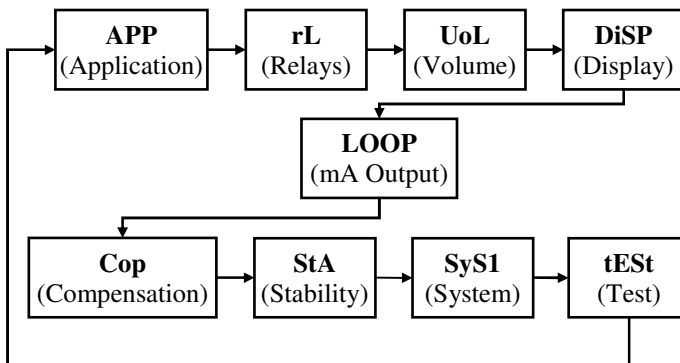

As you press the UP and DOWN buttons to scroll left and right between the menu options, you can press **ENTER** at any time to select a specific menu which will then take you to the parameters within the selected menu.

Once you have reached the relevant menu, scroll through the parameters, and enter the necessary information. To enter the information, use the UP and DOWN keys to increment or decrement the digit, and the ENTER key to shift the flashing digit to the next position, once you have completed entering the value required pressing the ENTER button again will save the value.

When you have finished, press **CANCEL** to go back to the previous level. When you have reached the top level, then the **IMP+** will ask for confirmation before allowing you to go back into run mode. This is done by pressing **ENTER** at the display prompt.

## **Parameter Defaults**

### **Factory Defaults**

#### **Factory Defaults**

When first installing the **IMP+**, or subsequently moving or using the unit on a new application, before proceeding to program the unit for its intended application it is recommended that you ensure that all parameters are at their default values by completing a **Factory Defaults P930**, as described in Chapter 5 **Parameter Guide**.

When you first switch the **IMP+** on, it will be reading the **distance** from the face of the transducer to the material surface. It will be indicating in **metres**, as shown on the display. All relays are set OFF.

#### **TIP**



In some applications it is simplest to empty the vessel, take a reading from the Imp for distance and then setup the empty level to this figure.

Once you are satisfied with the installation, and the **IMP+** is reading what you would expect in terms of distance from the face of the transducer to the material level, then you can proceed with programming, for the intended application. It is sensible to program all of the required parameters at the same time. The system will be then set-up.

*Note that the span is automatically calculated from the empty level, so the empty level should be entered first.*

This chapter explains how to undertake the various functions of your  $\text{IMP}^+$ . Where specific parameters are used, consult Parameter Guide in Chapter 5.

### Setting up Your Application

#### Empty Distance

**Empty Distance (P105)** is the distance from the face of the transducer to the material at the bottom of the vessel.

#### Span

**Span (P106)** is the distance from the empty level (0% full) to span (100% full).

#### Near and Far Blanking

**Near blanking (P107)** is the distance from the face of the transducer that the Imp will not record a level nearer than. A typical reason to increase this from the default value would be if you wish to ignore close in obstructions.

**Far blanking (P108)** is the distance (as a percentage of empty level) beyond the empty level that the Imp will read, the default is plus 20% of empty level. If you wish to monitor further than the **empty level**, then increase this figure, so that the **empty level** plus the **far blanking** figure (as % of empty level) is greater than the surface being measured, within the capability of the transducer being used.

### Using the 4-20 mA Output

The mA output can be used to monitor remotely what the  $\text{IMP}^+$  is showing, so it can be displayed remotely, integrated into a PLC, or used to generate a record using a chart recorder or similar.

By default, the  $\text{IMP}^+$  will provide a 4-20 mA output that represents what is displayed on the Imp, but these parameters can be overwritten as follows.

By default, the 4-20 mA will represent the empty level (4mA) and 100% of the operational span (20mA), but you may wish to only represent a section of the operational span. For example, the application may have an operational span of 6 metres, but you may only wish to represent empty level to 5 metres. If so, change **P834 (Low Value)** to 0, and **P835 (High Value)** to 5.0.

If the device connected to the mA output is out of calibration, and cannot be calibrated, then the low and high current levels can be trimmed by altering **P838 (Low Trim)** and **P839 (High Trim)**. To do this, simply enter the value that ensures that 4 mA or 20 mA respectively are shown on the remote device. You can use the left/right menu keys to alter the value until the correct reading is shown on the remote device, rather than typing in a value.

## Using the Relays

All relay related parameters are prefixed with a **2\*\*** .

The second digit of the three figure parameter number denotes the relay number as follows:

**2 1\*** parameters for Relay 1

**22\*** parameters for Relay 2

The third digit selects specific parameters for the setting up of the relays, which can be selected individually and results in the following parameter numbers for each relay.

Relay 1 **210** to **218**

Relay 2 **220** to **228**

Each relay can be configured in any of the options shown below, and usually has two associated set-point values with it (e.g. level) for ON and OFF.

### Note

When relays are programmed to act as Level Alarms relay setpoints are set in relation to the level of the material in the vessel, irrespective of the setting of the mode of operation (P100).

You first need to decide which relays are to be used as alarms. The **first parameter** for each relay determines the **type** the relay will be (i.e. **not in use, alarm** or **control**.), and what the further relay parameters, applicable to your selection, represent. Each of these types will now be described.

There are three **types** that each relay, individually, can be set to, for example, consider **Relay 1**, you can select parameter **P210** from the following options:

- 0 = Not in Use**      relay will remain in the de-energised condition.
- 1=Alarm:**            relay will de-energise to set the alarm “ON”.
- 2=Control**            relay will energise to set the control “ON”.

**Alarm Relay Set-up**

The alarm relays are de-energised to turn the alarms “ON”, and energised to turn the alarms “OFF”. In this way, loss of power will ensure that the alarm is activated.

To set an **alarm** relay, set the **first parameter** for the relay to equal **1**

E.g.      Setting **Relay 1** for alarm purposes **P210 = 1**

            Setting **Relay 2** for alarm purposes **P220 = 1**

The **second parameter** for each relay determines the **function** of the alarm relay, using the example of **Relay 1**, the **alarm function** can be selected from the options available in parameter **P211**.

For full details of all available alarm options please refer to **P211, 221 Relay Function... If P210, 220 = 1(Alarm)** tables in Chapter 5.

The **third parameter**, and the **fourth parameter** for each relay set the **Alarm “ON”** and **“OFF”** points. For a **high alarm** then set **“ON” higher than “OFF”**. For **low alarm** then set **“ON” lower than “OFF”**. Using the example of **Relay 1 P213** and **P214** set the **“ON”** and **“OFF”** points.

For example using **Relay 1**

<b>High Alarm</b>	<b>Low Alarm</b>
<b>P213 “ON” Setpoint</b>	<b>P213 “ON” Setpoint</b>
Higher than	Lower than
<b>P214 “OFF” Setpoint</b>	<b>P214 “OFF” Setpoint</b>

## **Control Relay Set-up**

The control relays are energised to turn the control “ON” (start process function), and de-energised to turn the control “OFF” (stop process function). In this way, loss of power will ensure that the pumps are turned “OFF”.

To set a **control** relay, set the **first parameter** for the relay to equal **2** (for control).

E.g.      Setting **Relay 1** for control purposes **P210 = 2**

                 Setting **Relay 2** for control purposes **P220 = 2**

The **second parameter** for each relay determines the **function** of the control relay, using the example of **Relay 1**, the **control function** can be selected from the options available in parameter **P211**.

For full details of all available alarm options please refer to **P211, 221 Relay Function... If P210, 220 = 2(control)** tables in Chapter 5.

The **third parameter** and **fourth parameter** are set to determine the switch points for the **control** relay. The **control** functions are started and stopped at the “ON” and “OFF” setpoints. To set a **control down** function (reduce level) then set “ON” **higher than** “OFF”. To set a **control up** function (increase level) then set “ON” **lower than** “OFF”.

For example using Relay 1

<b>Control Down</b>	<b>Control Up</b>
<b>P213</b> “ON” Setpoint	<b>P213</b> “ON” Setpoint
Higher than	Lower than
<b>P214</b> “OFF” Setpoint	<b>P214</b> “OFF” Setpoint

## **Loss of Echo Set-up**

When a relay is assigned to Loss of Echo (LOE) or fault condition, it will be set as an alarm relay which will be de-energised to turn the alarm (LOE) “ON”, and energise to turn the alarm (LOE) “OFF”. In this way, loss of power will ensure that the alarm is activated.

To set an **alarm** relay, set the **first parameter** for the relay to equal **1**

E.g.      Setting **Relay 1** for Alarm purposes **P210 = 4**

**When a relay is assigned to LOE no further parameters are required.**

## **Other Relay Parameters**

### **Fail-safe Mode**

Your  $\tau\text{MP}+$  has a general fail-safe parameter **P808**. This parameter will determine what state (level) both the **display** and the **relays** will assume in the case of a **fault** condition (**Loss Of Echo**).

The fail-safe values for **P808** are as follows: **1= Hold** last known value, **2= Fail High**, **3= Fail Low**.

## **Setting Security Passcodes**

A passcode is used to switch the  $\tau\text{MP}+$  from **Run Mode** into **Program Mode**.

You can set a new passcode to prevent anyone changing any of your settings within your  $\tau\text{MP}+$ . The default **passcode** is **1997**, but this may be changed as follows.

### **Additional Information**

The passcode is also used for remote access using the RS232, so if this is being used, be sure to ensure any additional equipment using this feature is changed accordingly.

## **Using A Passcode**

If you don't want to use a passcode, you can disable it as follows. First, enter **Program Mode** and go to the **SyS1** (System) menu. Select **P921** which is the **passcode enable** parameter.

As shown on the display, setting the passcode enable to '0' will **disable** it, or '1' will **enable** the use of passcode.

### **Additional Information**

If the use of a passcode has been disabled, then you can move straight into Program Mode from Run Mode by pressing the **ESC** and **ENTER** button simultaneously.

## **Changing The Passcode**

You can set the **passcode** to any number from 0000 to 9999. To do this, enter **Program Mode** and go to **SyS1** (System) menu. Select **P922** which is the **Passcode** parameter which can be changed as required.

## **Resetting Factory Defaults**

If you need to restore parameters to their original factory settings, then enter **Program Mode** go to the **SyS1** (System) menu and **ENTER**. Using the UP and DOWN buttons, go to parameter **P930**, and **ENTER**, **P930** is the factory defaults parameter, change the value to **1** and **ENTER**, all parameters, with the exception of the mA trims, will be restored to the factory settings (including the DAtEM trace) and on completion Stor (Store) will be displayed after which you can ESC out of this parameter and continue programming the **IMP+** for the required application.

## **Checking the Information Specific to your IMP+**

There are some parameters dedicated to each individual **IMP+**, such as the software revision and the units serial number.

## **Checking the Software Revision and Serial Number**

If you need to identify the serial number of the unit or the current level of software in your **IMP+**, whilst in **Run Mode** press the **ESC** button and the serial number along with the software revision will be displayed. Alternatively enter **Program Mode** and select **SyS1** (System) menu and **ENTER**. Select parameter **P926** to view the identity of the current **software revision** or **P928** for the **serial number** of the unit.

## **Using the RS232 Serial Interface**

The RS232 serial interface is used to communicate between the **IMP+**, and a PC using the optional Pulsar IMP PC software, this software is used to obtain information from the **IMP+** so that echo traces can be viewed, parameters can be uploaded, downloaded and saved.

To do so, the settings for communications control are set as follows and cannot be changed: **baud rate 19,200, 8 data bits, no parity, 1 stop bits**.

Connection between the **IMP+** and the PC is made via RJ11 connector located under the lid of the **IMP+**.

**Note**

When **IMP+** is wired as a 2 wire device connecting to the RS232 RJ11 port will cause the **IMP+** to draw 20mA, this is necessary to ensure correct operation of the RS232.

### Parameter Listing

This chapter describes all of the parameters contained within the **IMP+**.

### Application (APP) Menu

#### P100 Mode of Operation

This parameter sets the mode of operation, when in run mode, and can be set to one of the following:

Option	Description
1= <b>Distance (Default)</b>	Display shows the distance from the transducer face to the surface.
2= Level	Display shows how full the vessel is.
3= Space	Display shows how empty a vessel is.
4= Volume	Display shows volume of material in the vessel

#### P104 Measurement Units

This parameter sets the units you want to use for programming and display

Option	Description
1 = metres	All units of measure are <b>METRES</b>
2 = cm	All units of measure are <b>CENTIMETRES</b>
3 = mm	All units of measure are <b>MILLIMETRES</b>
4 = feet	All units of measure are <b>FEET</b>
5 = inches	All units of measure are <b>INCHES</b>

#### P105 Empty Level

This parameter is to be set to the maximum distance from the face of the transducer to the empty point, in **P104 Measurement Units**. Note this value affects span as well, so should be set before span. **Default: IMP 3 = 3.00m (9.84 feet), IMP 6 = 6.00m (19.69 feet) and IMP 10 = 10.00m (32.81 feet).**

## P106 Span

This parameter should be set to the maximum distance from the **Empty Level (P105)** to the maximum material level. It is automatically set to be equal to the **Empty Level (P105)** less the **Near Blanking distance (P107)**, when you set the empty level. **Default IMP 3 = 2.80m (9.19 feet)**, **IMP 6 = 5.70m (18.70 feet)** and **IMP 10 = 9.70m (31.82 feet)**.

## P107 Near Blanking Distance

This parameter is the distance from the face of the transducer that is not measurable, and is pre-set to the minimum value dependant on the version of **IMP+** being used. It should not be set to less than this figure, but can be increased.

<b>IMP+ Version</b>	<b>Near Blanking Distance</b>
IMP 3 metre	Default Blanking Distance = 0.2m (0.66 feet)
IMP 6 metre	Default Blanking Distance = 0.3m (0.98 feet)
IMP 10 metre	Default Blanking Distance = 0.3m (0.98 feet)

## P108 Far Blanking Distance

This is the distance (as a **percentage** of empty level) beyond the empty point that the unit will be able to measure, and the **default** is pre-set to **10%** of the empty level.

If the surface being monitored can extend beyond the **Empty Level (P105)** then the far blanking distance can be increased to a maximum of **100%** of empty level.

This parameter is always entered as a *%* of empty level.

## Relay (rL) Menu

### P210 (Relay 1), P220 (Relay 2) - Relay Type

This parameter defines what type each relay should be, see the table below for available options.

Option	Description
0= Not in Use (Default)	Relay not programmed.
1= Alarm	Relay is programmed as an alarm relay, which will <b>de-energise ON</b> , and <b>energise OFF</b> . This will ensure an alarm is raised if the power fails to the unit.
2 = Control	Relay is programmed as a control relay, which will energise ON, and de-energise OFF.

## Alarms

P210 (Relay 1), P220 (Relay 2) =1 (Alarm)

P211 (RL1), P221 (RL2) - Relay Function

This parameter defines what **function** the **alarm** will respond to as follows.

Option	Description
0= Off (Default)	Relay will not operate.
1= Level	Alarm is based on the level in the vessel, and the type of level alarm (P212, 222) and two setpoints must be set (P213, 223 & P214, 224). Setpoints are entered in Display Units or % of span as referenced to Empty Level <sup>*</sup> .
4= Loss of Echo	Alarm is raised if the <b>Failsafe Timer (P809)</b> expires. No setpoints are required.

### **P213 (Relay 1), P223 (Relay 2) - Relay “ON” Setpoint**

This parameter determines the “ON” point for the alarm and should be set as follows, in **Measurement Units P104**

<b>High Alarm</b>	<b>Low Alarm</b>
P213/P223 “ON” Setpoint	P213/P223 “ON” Setpoint
<b>Higher than</b>	<b>Lower than</b>
P214/P224 “OFF” Setpoint	P214/P224 “OFF” Setpoint

### **P214 (Relay 1), P224 (Relay 2) - Relay “OFF” Setpoint**

This parameter determines the “OFF” point for the alarm and should be set as follows, in **Measurement Units P104**

<b>High Alarm</b>	<b>Low Alarm</b>
P214/ P224 “OFF” Setpoint	P214/ P224 “OFF” Setpoint
<b>Lower than</b>	<b>Higher than</b>
P213/P223 “ON” Setpoint	P213/P223 “ON” Setpoint

### **LOE (Loss Of Echo)**

No setpoints are required when relays are used as LOE (Loss Of Echo)

### **Control**

**P210 (Relay 1), P220 (Relay 2) =2 (Control)**

**P211 (Relay 1), P221 (Relay 2) - Relay Function,**

This parameter defines whether the **general control** relay function is currently “ON” or “OFF”.

<b>General Control</b>	<b>Description</b>
<b>0= Off (Default)</b>	Relay is always de-energised.
1= On	Control is based on the level in the vessel. All general controls are used to assist each other (run at the same time) and each general control has its own “ON” and “OFF” setpoints.

### **P213 (Relay 1), P223 (Relay 2) - Relay “ON” Setpoint**

This parameter determines the “ON” point for the control relay and should be set as follows, in **Measurement Units P104**

<b>Control Down</b>	<b>Control Up</b>
<b>P213/P223 “ON” Setpoint</b>	<b>P213/P223 “ON” Setpoint</b>
<b>Higher than</b>	<b>Lower than</b>
P214/P224 “OFF” Setpoint	P214/P224 “OFF” Setpoint

### **P214 (Relay 1), P224 (Relay 2) - Relay “OFF” Setpoint**

This parameter determines the “OFF” point for the control relay and should be set as follows, in **Measurement Units P104**

<b>Control Down</b>	<b>Control Up</b>
<b>P214/ P224 “OFF” Setpoint</b>	<b>P214/ P224 “OFF” Setpoint</b>
<b>Lower than</b>	<b>Higher than</b>
P213/P223 “ON” Setpoint	P213/P223 “ON” Setpoint



## Volume (UoL) Menu

### P600 Vessel Shape

This parameter determines which vessel shape is used when utilising “Volume Conversion”.

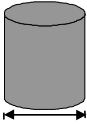
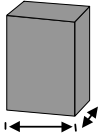
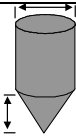
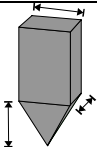
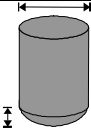
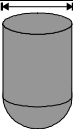
The choices are as shown in the table below, along with the **dimensions** that are required to be entered (**P601-P603**).

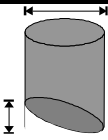
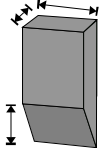
Vessel Shape	P600 Value	Dimensions Required
	P600=0 Cylindrical Flat base (Default)	Cylinder diameter
	P600=1 Rectangular Flat base	Width and Breadth
	P600=2 Cylindrical Cone base	Cylinder diameter and height of bottom
	P600=3 Rectangular Pyramid base	Width and Breadth of rectangular section and height of bottom
	P600=4 Cylindrical Parabola base	Cylinder diameter and height of bottom
	P600=5 Cylindrical Half-sphere base	Cylinder Diameter

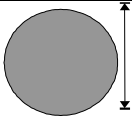
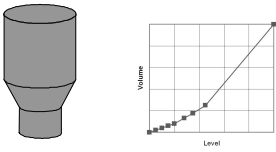
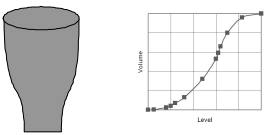
Vessel Shape	P600 Value	Dimensions Required
	P600=6 Cylindrical Flat sloped base	Cylinder diameter and height of bottom
	P600=7 Rectangular Flat sloped base	Width and Breadth of rectangular section and height of bottom
	P600=8 Horizontal cylinder with flat ends	Cylinder diameter and tank length
	P600=9 Horizontal cylinder with parabolic ends	Cylinder diameter, length of one end section, and tank length
	P600=10 Sphere	Sphere diameter
	P600=11 Universal Linear	No dimensions required, level and volume breakpoints used. <b>Entered via IMP PC</b>
	P600=12 Universal Curved	No dimensions required, level and volume breakpoints used. <b>Entered via IMP PC</b>

## P601-P603 Vessel Dimensions

These three parameters are used to enter the dimension required to calculate the volume. The dimensions required are as shown below.

Vessel Shape	P601	P602	P603
P600=0 Cylindrical Flat base	Cylinder Diameter		
P600=1 Rectangular Flat base		Width of rectangle	Breadth of rectangle
P600=2 Cylindrical Cone base	Height of base	Cylinder Diameter	
P600=3 Rectangular Pyramid base	Height of base	Width of rectangle	Breadth of rectangle
P600=4 Cylindrical Parabola base	Height of base	Cylinder Diameter	
P600=5 Cylindrical Half-sphere base	Cylinder Diameter		
P600=6 Cylindrical Flat sloped base	Height of base	Cylinder Diameter	
P600=7 Rectangular Flat sloped base	Height of base	Width of rectangle	Breadth of rectangle
P600=8 Horizontal cylinder with flat ends	Length of Cylinder	Cylinder Diameter	
P600=9 Horizontal cylinder with parabolic ends	Length of Cylinder	Cylinder Diameter	Length of one end section
P600=10 Sphere	Sphere Diameter		

## P604 Calculated Volume

This parameter displays the maximum volume that has been calculated by the **IMP+** and is a Read Only parameter. The volume displayed will be shown in cubic meters and is the total volume available between **empty level (P105)** and 100% of **span (P106)**.

## P605 Volume Units

This parameter determines the units that you wish to display, for volume conversion. It is used in conjunction with **P607 (maximum volume)**, and the units are shown on the display (subject to P810).

The choices are:

Option	Description
0 = No Units	Volume will be totalised with <b>no units</b>
1 = Tons	Volume will be totalised in <b>Tons</b>
2 = Tonnes	Volume will be totalised in <b>Tonnes</b>
3 = Cubic metres	Volume will be totalised in <b>cubic metres</b>
4 = Litres	Volume will be totalised in <b>litres</b>
5 = UK Gallons	Volume will be totalised in <b>UK Gallons</b>
6 = US Gallons	Volume will be totalised in <b>US Gallons</b>
7 = Cubic feet	Volume will be totalised in <b>cubic feet</b>
8 = Barrels	Volume will be totalised in <b>barrels</b>

## P606 Correction Factor

This parameter is used to enter a correction factor, when required, such as the specific gravity of the material so that the volume calculated is relative to the actual amount of material that can be contained between **empty level (P105)** and 100% of **span (P106)**. **Default = 1**

## P607 Max Volume

This parameter displays the actual maximum volume that has been calculated by the  $\pm MP$ , i.e. **P604 Calculated Volume x P606 Correction Factor**, and is a Read Only parameter. The volume displayed will be shown in **P605 Volume Units** and is the total volume available between **empty level (P105)** and 100% of **span (P106)**.

## Display (DiSP) Menu

### P800 Display Units

This parameter determines whether the reading displayed is in **Measurement Units (P104)**, or as a **percentage of span**.

Option	Description
1 = Measured (Default)	Display is in <b>Measurement Units (P104)</b>
2 = Percentage	Display is in <b>percentage</b> of span.

## P801 Decimal Places

This parameter determines the number of decimal places on the reading during run mode.

Minimum = 0 (No decimal places), Maximum 3 = (3 decimal Places)

**Default = 2**

## P808 Fail-safe Mode

By default, if a fail-safe condition occurs, then the display, relays and the mA output are held at their last **known** values until a valid reading is obtained.

If required, then you can change this so that the unit goes to **high** (100% of span), or **low** (empty) as follows:

Option	Description
1 = <b>Known (Default)</b>	Remain at the last <b>known</b> value
2 = High	Will fail to the <b>high</b> value (100% of Span).
3= Low	Will fail to the <b>low</b> value (empty)

### P840 mA Output Fail-safe

## P809 Fail-safe Time

In the event of a fail-safe condition occurring the fail safe timer determines the time before fail-safe mode is activated. **Default = 2.00 mins**

If the timer activates, the unit goes into **fail-safe**, as determined by **P808**, (**Display** and **P840 (mA Output)**). When this happens, you will see the message “**LOE!**” on the display.

When a valid measurement is obtained then the display, relays and mA output will be restored and the timer is reset.

## mA Output (LOOP) Menu

### P834 mA Low Level

This parameter sets the distance, level or space, depending on the selected **Mode of Operation (P100)**, at which 4mA will occur.

### P835 mA High Level

This parameter sets the distance, level or space, depending on the selected **Mode of Operation (P100)**, at which 20 mA output will occur.

### P838 mA Low Trim

If the device you are connected to is not calibrated, and not showing the low value, then you can trim it using this parameter. You can either type in the offset directly, or use the arrow keys to move the output up and down until you get the expected result on the device that is connected.

### P839 mA High Trim

If the device you are connected to is not calibrated, and not showing the high value, then you can trim it using this parameter. You can either type in the offset directly, or use the arrow keys to move the output up and down until you get the expected result on the device that is connected.

### P840 mA Fail-safe Mode

This parameter determines what happens to the mA output in the event of the unit going into fail-safe mode. The **default** is to do the same as the **system fail-safe (P808)**, but this can be overridden to force the mA output to an independent fail-safe mode as follows:

Option	Description
0 = Default	mA output will fail as per <b>P808</b> .
1 = Hold	mA output will retain its last known value.
2 = Low	mA output will fail to its <b>low</b> condition. <b>3.5mA</b>
3 = High	mA output will fail to its <b>high</b> condition. <b>22mA</b>

### P842 Voltage Output

This parameter will determine the **range** of the **voltage output**. The voltage output will **automatically** be **scaled** to represent the **Span P106** where **0volts** represents 0% (**empty**) and maximum voltage **5** or **10 volts**, depending on range selected, will represent 100% (**full**).

Option	Description
0 = 5 volts	Voltage output range will be 0 - 5volts.
1 = 10 volts	Voltage output range will be 0 - 10volts.

#### Additional Information

In the event of a **failsafe** condition **occurring**, the **voltage output** will fail in accordance with the **Failsafe Mode P808**

## Compensation (CoP) Menu

### P851 Measurement Offset

The value of this parameter is added to the measured distance, in **Measurement Units (P104)**.

This Offset will be added to the level, as derived from the transducer, and will affect everything including the reading on the display, the relay setpoints and the mA output.

### P852 Temperature Source

Default = 1
-------------

This parameter determines the source of the temperature measurement. By **default** it is set to internal (transducer) (**P852=1**), which will automatically detect the temperature from the transducer. If for any reason, no temperature input is received, then the **Fixed Temp** value is used, as set by **P854**.

The temperature source can be specifically set as follows:

Option	Description
1 = Internal (Default)	Always uses temperature reading from transducer.
3 = Fixed	Always uses fixed temperature (P854)

### P854 Fixed Temperature

This parameter sets the temperature, in degrees centigrade to be used if **P852 (Temperature Source) =3**. **Default = 20°C**

### P860 Sound Velocity

This option allows for the velocity of sound to be changed according to the atmosphere the transducer is operating in. By **default** the velocity is set for **342.72m/sec** which is the speed of sound travelling in air at a temperature of **20°C**.

The table below gives details of the velocity of sound in various gaseous atmospheres. In all cases the velocity indicated is that in a 100% gaseous atmosphere at 0°C. In atmospheres less than 100% it may be necessary to check the level indicated at near empty and near full and compare with the actual level, several times, then adjust the **Sound Velocity** accordingly to obtain an accurately displayed reading.

Gas	Sound Velocity
Chlorine	206 m/sec
Argon	308 m/sec
Oxygen	316 m/sec
Air	331.5 m/sec
Ammonia	415 m/sec
Methane	430 m/sec
Helium	435 m/sec
Neon	965 m/sec

### **P645 Vapour Temperature Compensation**

The sound velocity in air increases or decreases at a uniform rate of 60cm/sec. per °C, however in atmospheres other than air it will change at a different rate.

This option allows the rate of change in cm/sec. per °C to be set according to the atmosphere and temperature present. The level indicated, should be compared with the actual level, several times, then **Vapour Temperature Compensation** adjusted accordingly, to obtain an accurately displayed reading. **Default = 60 cm/sec. per °C**

## Stability (StA) Menu

### **Damping**

Damping is used to damp the display, to enable it to keep up with the process but ignore minor surface fluctuations.

#### **P870 Fill Damping**

This parameter determines the maximum rate at which the unit will respond to an increase in level. It should be set slightly higher than the maximum vessel fill rate. **Default = 10.000 metres/minute (32.81 feet/minute)**

#### **P871 Empty Damping**

This parameter determines the maximum rate at which the unit will respond to a decrease in level. It should be set slightly higher than the maximum vessel empty rate. **Default = 10.000 metres/minute (32.81 feet/minute)**

## System (SyS1) Menu

*The following three parameters do not affect how the unit performs, but details, contained in them, may be required, by Pulsar, when making technical enquiries.*

### **P921 Enable Code**

**Enables** the passcode (**P922**), which means the passcode must be entered to go into program mode. If **disabled** (set to **0**), then no passcode is required, and pressing ESC and ENTER button simultaneously will allow entry into the program mode.

### **P922 Passcode**

This is the passcode that must be used to enter program mode. The **default** is **1997**, but this can be changed to another value.

### **P926 Software Revision**

This parameter will display the current software revision.

### **P928 Serial Number**

This parameter will display the serial number of the unit.

## **P930 Factory Defaults**

This parameter resets all parameter values to the original Factory Set values that were installed when the unit was tested, before despatch to you.

To **reset** parameters, enter **1** and press **ENTER**, all parameters, with the exception of the mA trims, will be restored to the factory settings (including the DATEM trace) and on completion Stor (Store) will be displayed after which you can ESC out of this parameter and continue programming the **IMP+** for the required application.

## **Test (tESt) Menu**

### **P991 Hard Test**

When this parameter is selected, the unit will test the following in turn.

- **Relays.** Press the **UP** button for **Relay 1** and the **DOWN** for **Relay 2**, the relay will change state each time the key is pressed. If you press any other key, other than a valid relay number, then the test will end.
- **Display.** All the segments on the LCD and the backlight are lit up, so you can see if they all work. Press the **ENTER** button, to end the test.
- **Keys.** You should press each button, to confirm it works, with a counter showing how many more buttons you have to press. Press **ESC** last, as this will show if all keys were pressed or not. If they were not, then an error message is displayed.

### **P992 mA Out Test**

This parameter will allow you to force a specified current on the mA output, to test the equipment that it is connected to, and to make sure the unit is working correctly. The figure you enter will be generated by the mA output.

## Chapter 6 Troubleshooting

This section describes many common symptoms, with suggestions as to what to do.

Symptom	What to Do
Display blank, transducer not firing.	Check power supply
Display shows "LOE".	No valid echo being received and unit has gone into fault condition. Check material level is not out of range, sensor is perpendicular to material surface.
Incorrect reading being displayed for current level.	Measure actual distance from transducer face to surface of material. Enter Program Mode and access <b>SyS1</b> menu, go to <b>P21</b> and press <b>ENTER</b> type in the <b>measured distance</b> , press <b>ENTER</b> , wait until " <b>Stor</b> " is displayed and return to Run Mode, display should now update to correct reading.
Material level is consistently incorrect by the same amount.	Check empty level (P105) correctly entered.

## Parameter Record

### APPLICATION (APP) MENU

Parameter Details		Entered Values					
No.	Description	Default	1	2	3	4	5
P100	Mode	1 = Dist.					
P104	Measurement Units	Model Dependant					
P105	Empty Level	Model Dependant					
P106	Span	Model Dependant					
P107	Near Blanking	Model Dependant					
P108	Far Blanking	10.0%					

### RELAYS (rL) MENU

Parameter Details		Entered Values					
No.	Description	Default	1	2	3	4	5
P210	Relay 1 Type	0 = Not in Use					
P211	Relay 1 Function	0 = Off					
P213	Relay 1 On point	0.000					
P214	Relay 1 Off point	0.000					

#### Relay 2

Parameter Details		Entered Values					
No.	Description	Default	1	2	3	4	5
P220	Relay 2 Type	0 = Not in Use					
P221	Relay 2 Function	0 = Off					
P223	Relay 2 On point	0.000					
P224	Relay 2 Off point	0.000					

### VOLUME (UoL) MENU

Parameter Details		Entered Values					
No.	Description	Default	1	2	3	4	5
P600	Vessel Shape	0					
P601	Vessel Dimension 1	0.00					
P602	Vessel Dimension 2	0.00					
P603	Vessel Dimension 3	0.00					
P604	Calculated Volume	Read Only					
P605	Volume Units	Model Dependant					
P606	Correction Factor	1					
P607	Max Volume	Read Only					

## DISPLAY (DisP) MENU

Parameter Details		Entered Values					
No.	Description	Default	1	2	3	4	5
P800	Display Units	1 = measured					
P801	Decimal Places	2					
P808	Fail Mode	1 = Known					
P809	Fail Time	2.0 mins					

## mA OUTPUT (LOOP) MENU

Parameter Details		Entered Values					
No.	Description	Default	1	2	3	4	5
P834	Low Level	0.000					
P835	High Level	Model Dependant					
P838	Low Trim	0.00 mA					
P839	High Trim	0.00 mA					
P840	Fail Mode	0 = Default					
P842	Voltage Out range	1 = 10volts					

## COMPENSATION (CoP) MENU

Parameter Details		Entered Values					
No.	Description	Default	1	2	3	4	5
P851	Measurement Offset	0.000					
P852	Temperature Source	1 = Automatic					
P854	Fixed Temperature	20.00 Deg. C					
P860	Sound Velocity	342.72 m/sec					
P645	Vapour Temp. Comp.	60cm/sec per °C					

## STABILITY (StA) Menu

Parameter Details		Entered Values					
No.	Description	Default	1	2	3	4	5
P870	Fill Damping	Model Dependant					
P871	Empty Damping	Model Dependant					

## SYSTEM (SyS1) MENU

Parameter Details		Entered Values					
No.	Description	Default	1	2	3	4	5
P921	Enable Code	1 = Yes					
P922	Passcode	1997					
P926	Software Revision	Read Only					
P928	Serial Number	Read Only					