

ELS-950/ELS-950M Series Rugged Electro-Optic Level Sensors

The ELS-950 and ELS-950M Series represents Gems' smallest electro-optic level sensors developed to monitor a broad range of media including OHV type fluids.

Our UL approved design features a TPE over-molded electronics insert, TPE insulated wires, and fluorocarbon o-ring seals that create a watertight, environmentally resistant assembly, ideally suited for use in harsh environments. Both series offer excellent temperature and pressure capabilities. With its brass housing and fused glass prism, the ELS-950M is built to be more durable in challenging environments, including outdoors and engine bays.

The ELS-950 and ELS-950M are excellent for industrial OEMs requiring a solid-state sensor for small space and high temperature environments.

Specifications

Materials	
Housing	
ELS-950	Polysulfone (Contact Gems for alternative material types)
ELS-950M	Brass
O-Ring	Fluorocarbon (1/4" MNPT - None)
Electronics	Over-molded TPE
Operating Pressure	0 to 250 PSI (0 to 17 bar) maximum
Operating Temperature*	-40°F to +230°F (-40°C to 110°C)
Current Consumptions (No Load)	
5 VDC	4 mA No Load
12 VDC	10mA No Load
Output	Sink 40 mA max., up to 30 VDC
Repeatability	±1 mm
Lead Wires	3x TPE Insulated; 22 AWG
Approvals	CE, UL file No. 108913 IP66/67 Rating Pending ROHS Compliant

* These switches are not for use in freezing liquids or steam/high condensation environments. Contact Gems for alternative solutions.

How To Order

Specify Part Number based on Input and Output Condition required.

Input Power	Actuation Condition	Housing	Lead Wire Length	Mounting Type		
				1/4" MNPT	1/2" - 20UNF-2B*	M12x1-8*
5 VDC ±10%	Wet	Brass	6 inches	232175	232171	232179
		Polysulfone	6 inches	224504 ⚡	224501 ⚡	224508 ⚡
			2 meters	226545	226541	226549
	Dry	Brass	6 inches	232176	232172	232180
		Polysulfone	6 inches	224505	224502 ⚡	224509 ⚡
			2 meters	226546	226542	226550
12 VDC ±10%	Wet	Brass	6 inches	232177	232173	232181
		Polysulfone	6 inches	224506 ⚡	224503 ⚡	224510 ⚡
			2 meters	226547	226543	226551
	Dry	Brass	6 inches	232178	232174	232182
		Polysulfone	6 inches	224507 ⚡	223625 ⚡	224511 ⚡
			2 meters	226548	226544	226552

* Supplied with standard fluorocarbon o-ring.

⚡ - Stock Items.

Supplied in the U.A.E. by:

Daly Fluid Technologies (L.L.C.)
 PO Box 26942, Abu Dhabi, U.A.E.
 T: +971 2 673 6349
 F: +971 2 673 6113
 PO Box 38362, Dubai, U.A.E.
 T: +971 4 885 2484
 F: +971 4 885 2474
 E: sales@dalyft.com
 W: www.dalyft.com

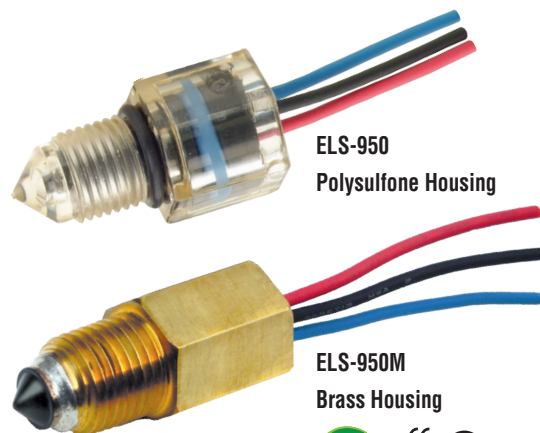

ELS-950
Polysulfone Housing

ELS-950M
Brass Housing



Typical Applications

- Coolant reservoir monitoring and warning
- Medical diagnostic, sterilizer, washers and dialysis equipment
- Low lubricant warning on machine tools, generator sets, on- or off-highway vehicles
- Low level warning in hydraulic reservoirs
- Plastic over flow bottles, plastic radiators
- Leak detection for drip pans

Dimensions

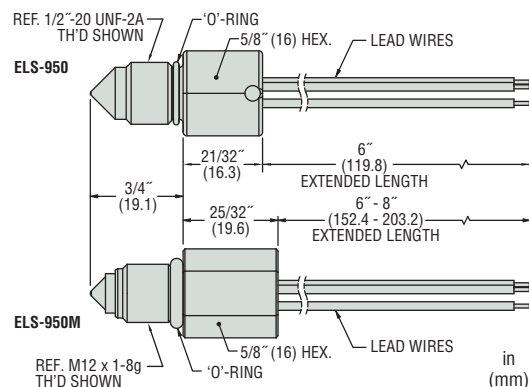

Wiring Diagrams

