

AquaProbe FEA100/FEA200

Electromagnetic flowmeter

Insertion-type flow sensors

Maximum performance,
minimum hassle



Introduction

The AquaProbe FEA100 / FEA200 flow sensor is designed for measurement of the velocity of water. The flow sensor is available in four standard lengths and can be installed in any pipeline of internal diameter from 200 mm (8 in.) to 8000 mm (360 in.), through a small tapping.

The flow sensor is designed for use in survey applications such as leakage monitoring and network analysis and in permanent locations where cost or space limitations preclude the use of conventional closed pipe meters.

This User Guide provides installation, connection, security, start-up and basic setup details for the flow sensor only. The AquaProbe sensor is available for operation with either a WaterMaster transmitter (FET100) or an AquaMaster 3 transmitter (FET200).

This User Guide should be used in conjunction with the following publications:

WaterMaster flowmeter (FEA100):

- User Guide – OI/FET100-EN
- Programming Guide – IM/WMP
- User Guide Supplement, PROFIBUS RS485 Physical Layer (FEX100-DP) – IM/WMPBS-EN
- User Guide Supplement, PROFIBUS FEX100-DP Parameter Tables – IM/WMPBST-EN

AquaMaster flowmeter (FEA200):

- User Guide – OI/FET200-EN
- Programming Guide COI/FET2XX-EN
- MODBUS Tables Supplement – COI/FET2XX/MOD/TBL-EN

ScrewDriver profiling and Configuration software:

- User Guide – OI/SDR

The Company

We are an established world force in the design and manufacture of instrumentation for industrial process control, flow measurement, gas and liquid analysis and environmental applications.

As a part of ABB, a world leader in process automation technology, we offer customers application expertise, service and support worldwide.

We are committed to teamwork, high quality manufacturing, advanced technology and unrivalled service and support.

The quality, accuracy and performance of the Company's products result from over 100 years experience, combined with a continuous program of innovative design and development to incorporate the latest technology.

Quality Control

The UKAS Calibration Laboratory No. 0255 is just one of the ten flow calibration plants operated by the Company and is indicative of our dedication to quality and accuracy.



UKAS Calibration Laboratory No. 0255

- 1 Safety 2**
 - 1.1 Electrical Safety 2
 - 1.2 Symbols 2
 - 1.3 Health & Safety 3

- 2 System Schematic 4**

- 3 Mechanical Installation 5**
 - 3.1 Location – Environmental Conditions 5
 - 3.2 Use 6
 - 3.3 Location – Flow Conditions 7
 - 3.3.1 International Standard for Flow Measurement 8
 - 3.3.2 Velocity Limitations 8
 - 3.4 Location – Mechanical 10
 - 3.5 Safety 11
 - 3.6 Installing the Flow Sensor 12
 - 3.7 Setting the Insertion Depth 13
 - 3.7.1 Centre Line Method for Pipe Diameters ≤ 1 m (≤ 40 in.) 13
 - 3.7.2 Centre Line Method for Pipe Diameters > 1 m ≤ 2 m (> 40 in ≤ 80 in.) 14
 - 3.7.3 Mean Axial Velocity Method 15
 - 3.8 Flow Sensor Alignment 16

- 4 Electrical Installation 17**
 - 4.1 Sensor Terminal Box Connections – WaterMaster FET100 Transmitter 17
 - 4.2 Environmental Protection 18
 - 4.3 Sensor Terminal Box Connections – AquaMaster 3 FET200 Transmitter 18

- 5 Setting Up 19**
 - 5.1 Introduction 19
 - 5.2 Centre Line Method 19
 - 5.3 Mean Axial Velocity Method (1/8 Diameter) 20
 - 5.4 Partial Velocity Traverse 20
 - 5.5 Transmitter Setup 20

- 6 Specification 21**

- Appendix A 24**
 - A.1 – Velocity Profiles Background 24
 - A.2 Testing the Flow Profile for Symmetry 26
 - A.2.1 Partial Velocity Traverse 26
 - A.2.2 Single Entry Point Method 26
 - A.2.3 Dual Entry Point Method 27
 - A.3 Full Velocity Profile 27

- Appendix B – Measuring the Internal Diameter 28**

1 Safety

Information in this manual is intended only to assist our customers in the efficient operation of our equipment. Use of this manual for any other purpose is specifically prohibited and its contents are not to be reproduced in full or part without prior approval of the Technical Publications Department.









1.1 Electrical Safety

This equipment complies with the requirements of CEI / IEC 61010-1:2001-2 'Safety Requirements for Electrical Equipment for Measurement, Control and Laboratory Use' and complies with NIST and OSHA.

If the equipment is used in a manner NOT specified by the Company, the protection provided by the equipment may be impaired.

1.2 Symbols

One or more of the following symbols may appear on the equipment labelling:

	Warning – Refer to the manual for instructions		Direct current supply only
	Caution – Risk of electric shock		Alternating current supply only
	Protective earth (ground) terminal		Both direct and alternating current supply
	Earth (ground) terminal		The equipment is protected through double insulation

1.3 Health & Safety

To ensure that our products are safe and without risk to health, the following points must be noted:

- The safety requirements of this equipment, any associated equipment and the local environment must be taken into consideration during installation.
- Install and use this equipment and any associated equipment in accordance with the relevant national and local standards.
- The relevant sections of these instructions must be read carefully before proceeding.
- Warning labels on containers and packages must be observed.
- Installation, operation, maintenance and servicing must be carried out only by suitably trained personnel and in accordance with the information given.
- Normal safety precautions must be taken to avoid the possibility of an accident occurring when operating in conditions of high pressure and / or temperature.
- Product liability – advice and assistance provided without charge is given in good faith but without liability.

Safety advice concerning the use of the equipment described in this manual or any relevant hazard data sheets (where applicable) may be obtained from the Company address on the back cover, together with servicing and spares information.

2 System Schematic

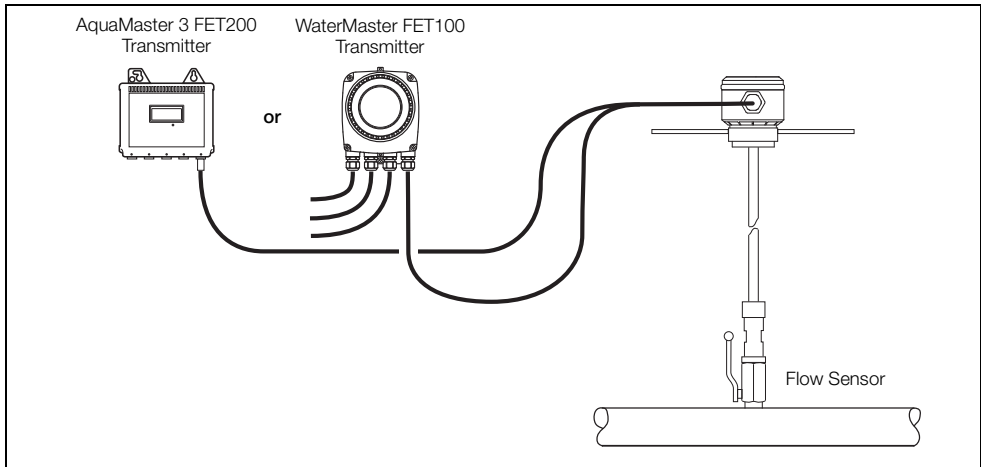

Fig. 2.1 System Schematic

Caution.

Care of the Equipment

- The tip of the flow sensor is a precision-built part of the equipment and must be handled with care.
- When the flow sensor is not in use, fully retract the tip and replace the end-cap.
- When removing / inserting the flow sensor into a pipeline, ensure the valve is fully open.
- Damage to the flow sensor affects the performance.
- Physical damage to the flow sensor invalidates the warranty.

3 Mechanical Installation

3.1 Location – Environmental Conditions

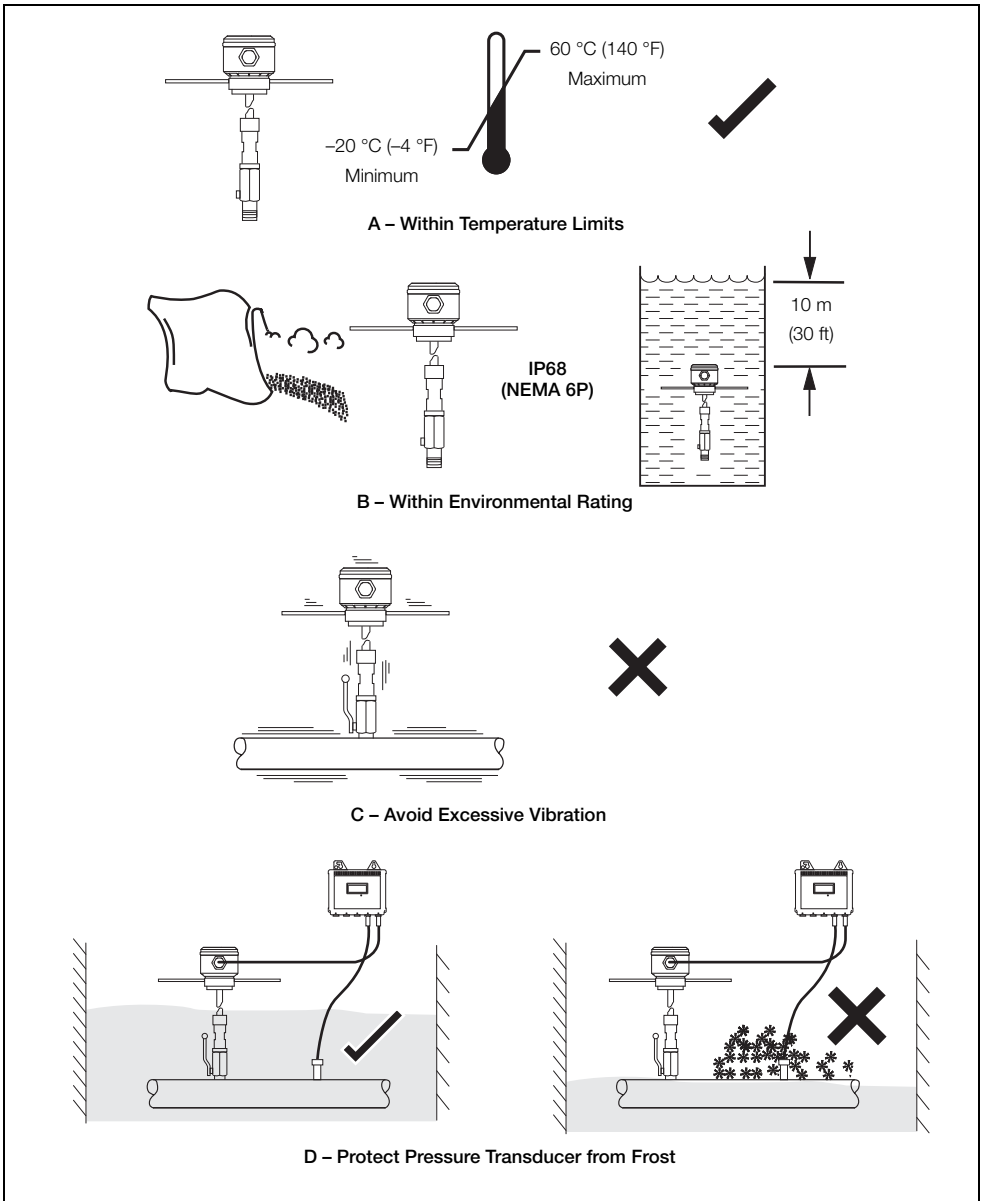

Fig. 3.1 Environmental Requirements

3.2 Use

An insertion probe is inserted into a flow-line through a small tapping and a valve fitted to the line. The tapping can be as small as one inch BSP or larger. Such a tapping is common on pipelines and, if one does not exist where it is required to make the installation, it is very inexpensive to fit one, online and under pressure, and there are many specialist companies that do this type of work.

Warning. Inserting a probe into a pressurized vessel (for example, a pipeline) can be dangerous. If the pressure in the pipeline is high (typically 5 bar or more), care must be used in both installing and removing the probe. If the pressure is greater than 10 bar, installation (or removal) of a probe is not recommended. Instead, remove the pressure from the pipeline for the short period of time it takes to install or remove the probe; the pressure can then be re-applied. In many instances, removal of a probe from a pressurized pipeline is more dangerous than installation. For this reason, AquaProbe is supplied complete with a safety device that prevents rapid outward movement and potential injury to operators. It must be stressed that this warning applies to all probe devices, not just AquaProbe.

3.3 Location – Flow Conditions

The flow sensor can be installed in one of two positions in the pipe:

- on the centre line
- or
- at the mean axial velocity point ($1/8$ pipe diameter)

It can also be traversed across the pipe to determine the velocity profile.

Note. When installing the sensor in a pipe, ensure the flow direction arrow on the flow sensor case matches the pipe flow direction.

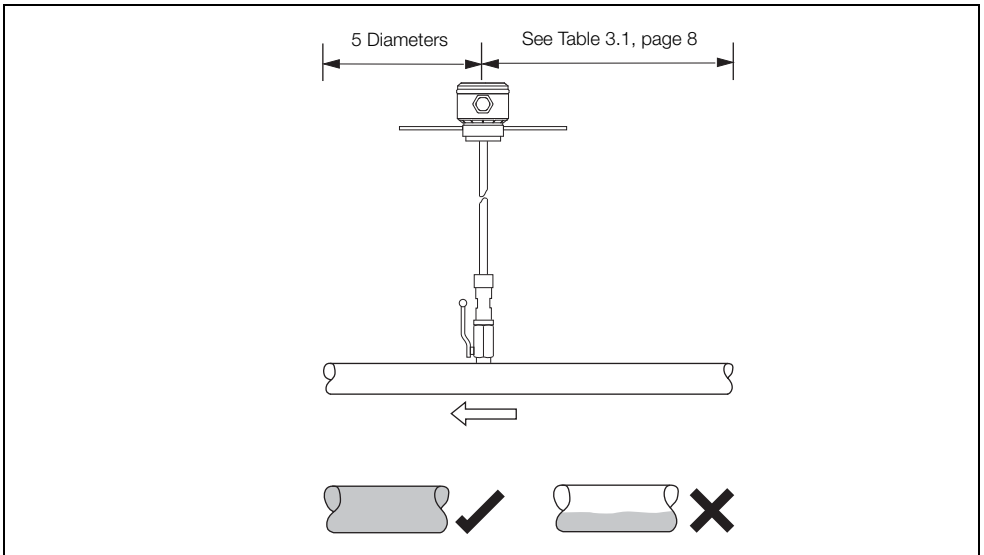

Fig. 3.2 Flow Conditions

3.3.1 International Standard for Flow Measurement

ISO 7145 (BS 1042) 'Measurement of fluid flow in closed conduits, Part 2 – Velocity area methods' describes methods of calculating volumetric flow from velocity measurements.

Section 2.2: 1982 'Method of measurement of velocity at one point of a conduit of circular cross section' describes the inference of volumetric flow from measurement of velocity at a single point. Several conditions must be fulfilled to validate the method, that uses calculations based on empirical data.

Where the validating conditions can be met, the method described in Section 3.3, page 7 is the most practical. It is possible to measure the velocity either on the centre line, which reduces sensitivity to positional errors, or at the assumed point of mean flow velocity.

Table 3.1 is an extract from ISO 7145 (BS 1042): Section 2.2: 1982 and is reproduced with the permission of BSI. Complete copies of the standard can be obtained by post from BSI Publications, Linford Wood, Milton Keynes, MK14 6LE.

Note. Where the above ideal conditions cannot be achieved, the flow profile must be tested for symmetry in order to obtain reliable flow results.

Type of disturbance upstream from the measuring cross-section	Minimum upstream straight length*	
	For a measurement at the point of mean axial velocity	For a measurement on the axis of the conduit
90° elbow or a t-bend	50	25
Several 90° coplanar bends	50	25
Several 90° non- coplanar bends	80	50
Total angle convergent 18 to 36°	30	10
Total angle divergent 14 to 28°	55	25
Fully opened butterfly valve	45	25
Fully opened plug valve	30	15

* Expressed in multiples of the diameter of the conduit.

Downstream from the measurement cross-section, the straight length shall be at least equal to five duct diameters whatever the type of disturbance.

Table 3.1 Straight Pipe Lengths

3.3.2 Velocity Limitations

All insertion flow sensor devices are susceptible to the vortex shedding effect that can cause severe vibration of the flow sensor, resulting in damage and/or measurement instability. Electromagnetic devices with no moving parts, such as flow sensors, are less susceptible to this effect than mechanical devices.

Fig. 3.4, page 9 shows the maximum permissible velocities, depending on the flow sensor's location.

This information is provided as a guide only. Some installations may experience unwanted vibration resonance that may further limit the maximum velocity at which the flow sensor can be used.

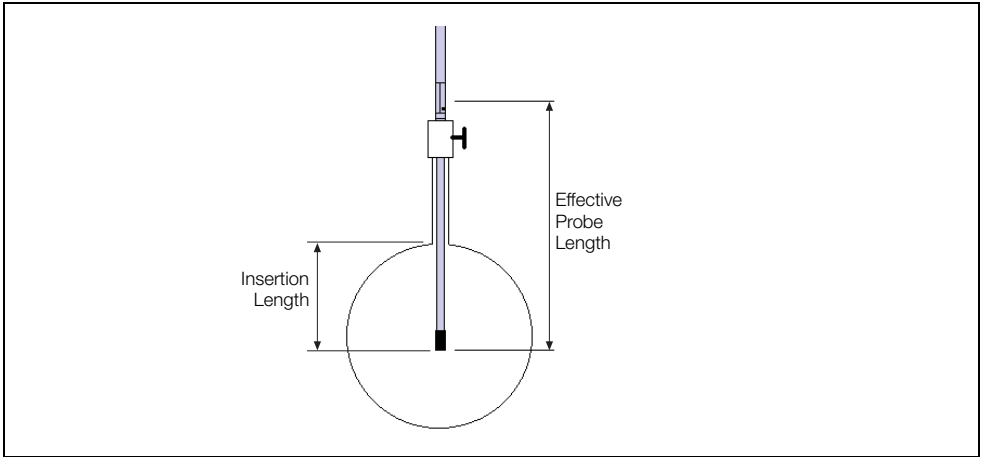

Fig. 3.3 Maximum Permissible Velocity for Different Pipe Sizes

It is important to add the external length from the fixing point to the insertion length. Failure to do this can give incorrect information from the graphs, resulting in vortex shedding affecting AquaProbe.

Examples:

- A 600 mm pipe with the probe mounted on the centre line has an insertion length of 300 mm.
- A typical valve is approximately 250 mm high and the distance to the support point inside the probe is approximately 100 mm therefore, in this example, the total effective length is 650 mm.
- Maximum velocity at 650 mm is 3.6 m/s.

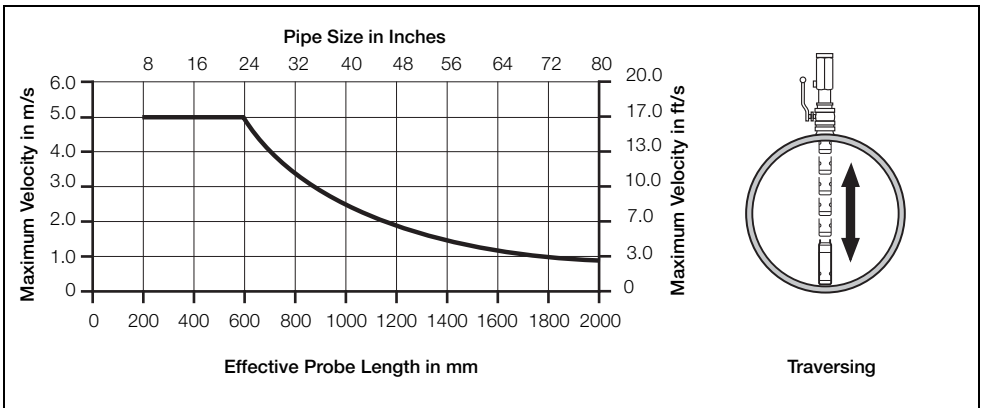
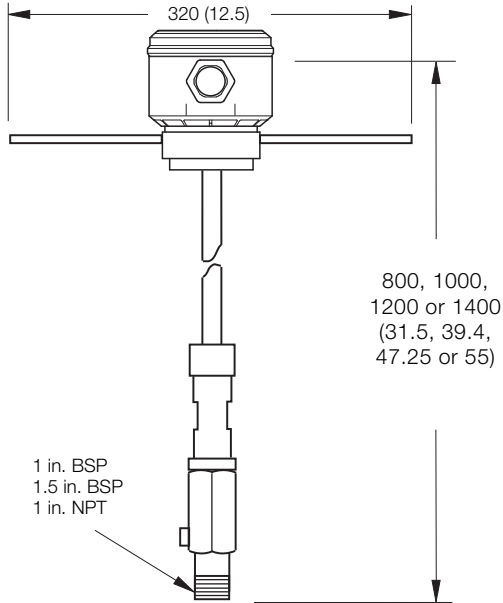

Fig. 3.4 Maximum Permissible Velocity for Different Insertion Lengths

3.4 Location – Mechanical

Note. Pipeline recommended to be metal for electrical screening.

Dimensions in mm (in.)



A – Clearance Dimensions

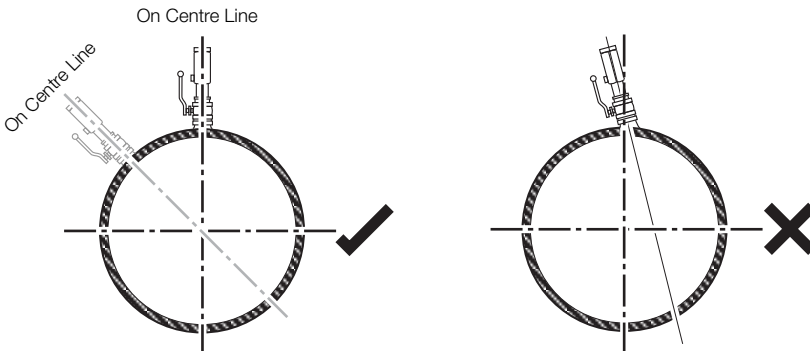

B – Orientation

Fig. 3.5 Mechanical Requirements

3.5 Safety

Warning. The flow sensor is provided with a safety mechanism (see Fig. 3.6A) that must be attached to its securing collar as shown in Fig. 3.6B. This prevents rapid outward movement by the flow sensor if nut (1) is released.

Note. To ensure maximum safety, the positioning collar **MUST** be tightened in place using a 4 mm hexagon key

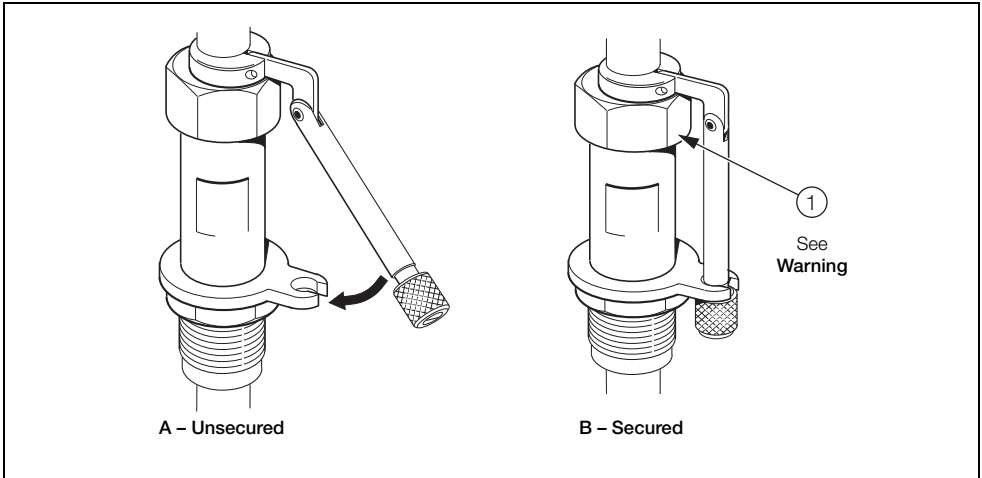

Fig. 3.6 Safety Mechanism

3.6 Installing the Flow Sensor

Warning. When inserting or removing the flow sensor, suitable restraining equipment **must** be used to prevent the flow sensor being forced out under pressure. Ensure that the valve is fully open.

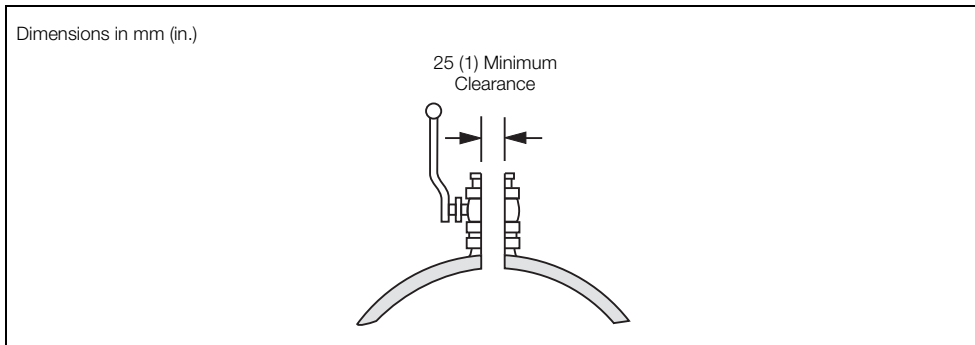

Fig. 3.7 Insertion Bore Clearance

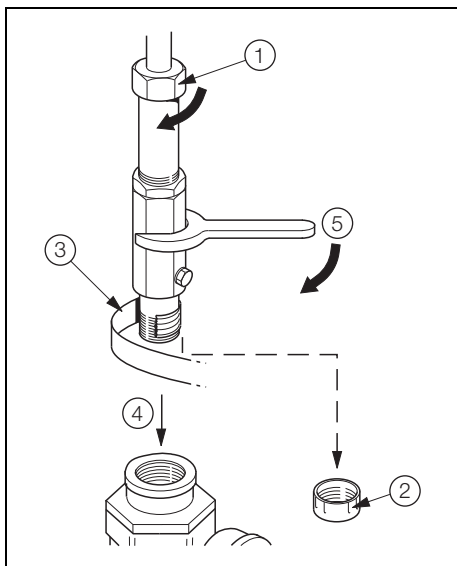

Fig. 3.8 Installing the Flow Sensor

Referring to Fig. 3.8:

- ① Tighten the nut (hand-tight only).
- ② Remove the cap.
- ③ Apply PTFE tape.
- ④ Insert the flow sensor into the valve.
- ⑤ Tighten firmly.

3.7 Setting the Insertion Depth

3.7.1 Centre Line Method for Pipe Diameters ≤1 m (≤40 in.)

Warning. When inserting or removing the flow sensor, suitable restraining equipment **must** be used to prevent the flow sensor being forced out under pressure. Ensure that the valve is fully open.

Note. Safety restraint omitted for clarity.

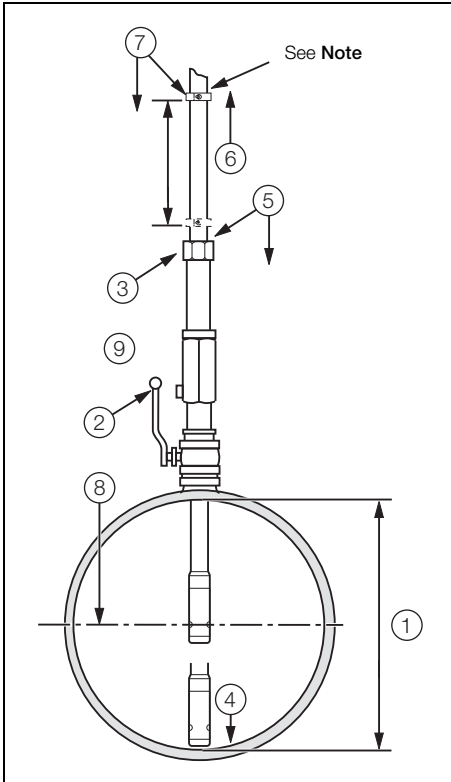

Referring to Fig. 3.9:

- ① Determine the internal diameter (D).
- ② Open the valve fully.
- ③ Slacken the nut.
- ④ Insert the flow sensor into the valve.
- ⑤ Slide the positioning collar down to the nut and lock in place.
- ⑥ Retract the flow sensor fully.
- ⑦ Unlock, slide the positioning collar down and lock at the distance:

$$\frac{D}{2} + 30 \text{ mm (1.181 in.)}$$
- ⑧ Insert flow sensor to position the collar depth.
- ⑨ Tighten to 40 Nm (30 ft lbf).

Fig. 3.9 Setting the insertion Depth – Centre Line Method for Pipe Diameters 1 m (40 in.)

3.7.2 Centre Line Method for Pipe Diameters >1 m ≤2 m (>40 in. ≤80 in.)

Warning. When inserting or removing the flow sensor, suitable restraining equipment **must** be used to prevent the flow sensor being forced out under pressure. Ensure that the valve is fully open.

Note. Safety restraint omitted for clarity.

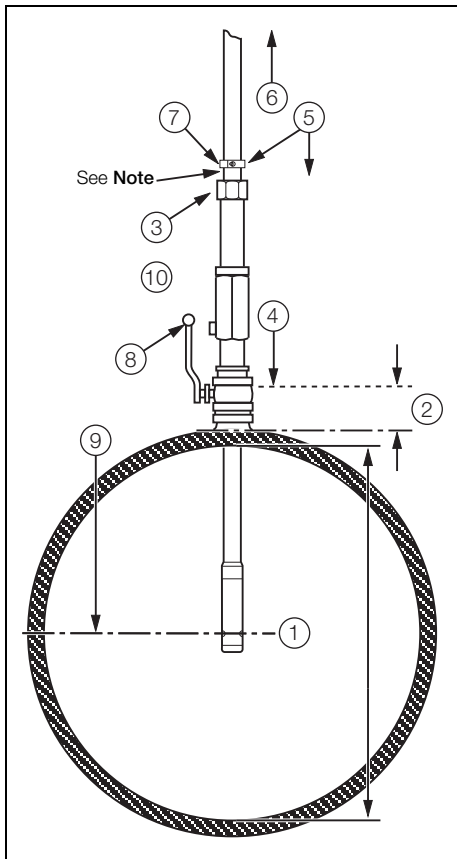

Fig. 3.10 Setting the Insertion Depth – Centre Line Method for Pipe Diameters >1 m 2 m (>40 in. 80 in.)

Referring to Fig. 3.10:

- ① Determine the internal diameter (D).
- ② Measure to the top of the valve plate (VP).
- ③ Slacken the nut.
- ④ Lower the flow sensor to touch the valve plate.
- ⑤ Slide the positioning collar down to the nut and lock in place.
- ⑥ Retract the flow sensor fully.
- ⑦ Unlock, slide the positioning collar down and lock at the distance:

$$\frac{D}{2} + VP + 30 \text{ mm (1.181 in.)} + \text{pipe thickness.}$$
- ⑧ Open the valve fully.
- ⑨ Insert flow sensor to position the collar depth.
- ⑩ Tighten to 40 Nm (30 ft lbf).

3.7.3 Mean Axial Velocity Method

Warning. When inserting or removing the flow sensor, suitable restraining equipment **must** be used to prevent the flow sensor being forced out under pressure. Ensure that the valve is fully open.

Note. Safety restraint omitted for clarity.

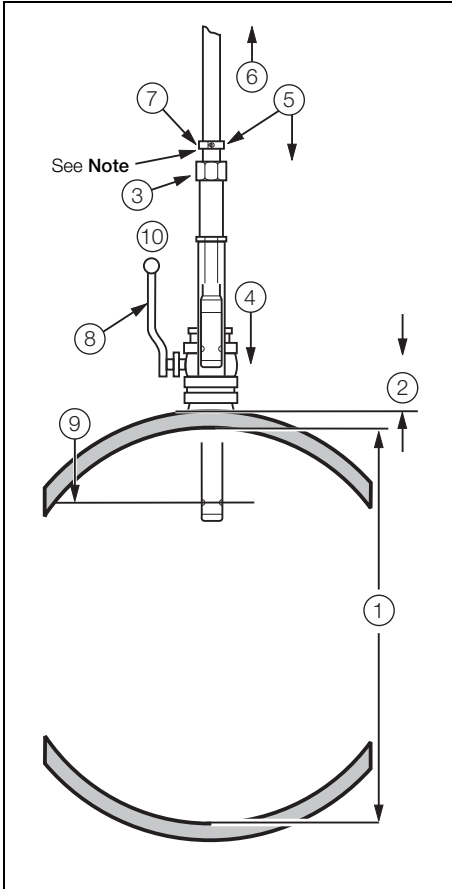

Referring to Fig. 3.11:

- ① Determine the internal diameter (D).
- ② Measure to the top of the valve plate (VP).
- ③ Slacken the nut.
- ④ Lower the flow sensor to touch the valve plate.
- ⑤ Slide the positioning collar down to the nut and lock in place.
- ⑥ Retract the flow sensor fully.
- ⑦ Unlock, slide the positioning collar down and lock at the distance:
 $\frac{D}{8} + VP + 30 \text{ mm (1.181 in.)} + \text{pipe thickness.}$
- ⑧ Open the valve fully.
- ⑨ Insert flow sensor to position the collar depth.
- ⑩ Tighten to 40 Nm (30 ft lbf).

Fig. 3.11 Setting the Insertion Depth – Mean Axial Velocity Method

3.8 Flow Sensor Alignment

Warning. When inserting or removing the flow sensor, suitable restraining equipment **must** be used to prevent the flow sensor being forced out under pressure. Ensure that the valve is fully open.

Note. Safety restraint omitted for clarity.

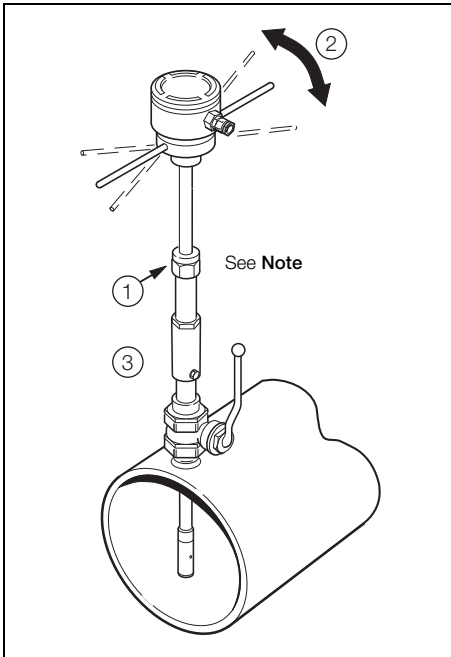

Referring to Fig. 3.12:

- ① Slacken the nut.
- ② Align parallel to the pipe (within 2°) – measurement error due to misalignment (of <2) is <0.15 %.
- ③ Tighten to 40 Nm (30 ft lbf).

Fig. 3.12 Flow Sensor Alignment

4 Electrical Installation

4.1 Sensor Terminal Box Connections – WaterMaster FET100 Transmitter

Caution.

- Make connections only as shown.
- Remove foil screens.
- Twist the three screen wires together and sleeve them.
- Twist cable pairs together.
- Maintain Environmental Protection at all times.
- Conduit connections must provide cable entry sealing.

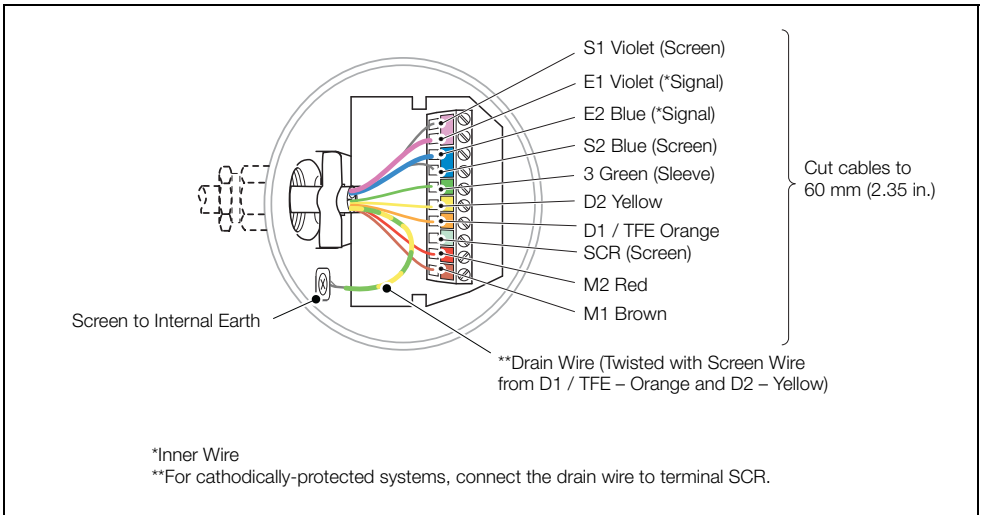

Fig. 4.1 Cable Connections at Flow Sensor Terminal Block – WaterMaster FET1 Transmitter

4.2 Environmental Protection

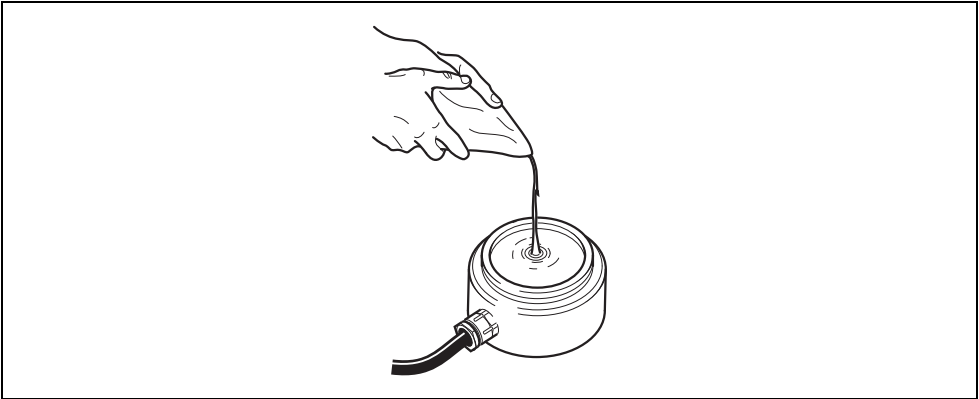

Fig. 4.2 Potting the Terminal Box – WaterMaster FET1 Transmitter

Warning.

- Potting materials are toxic – use suitable safety precautions.
- Read the manufacturers instructions carefully before preparing the potting material.
- The remote sensor terminal box connections must be potted immediately on completion to prevent the ingress of moisture.
- Check all connections before potting – see Section 4, Page 17.
- Do not overfill or allow the potting material to come into contact with O-rings or grooves.
- Do not let potting material enter conduit, if used.

4.3 Sensor Terminal Box Connections – AquaMaster 3 FET200 Transmitter

With AquaMaster 3 FET2 transmitter the sensor terminal box is factory-wired, potted and terminated with a plug for easy connection at the transmitter.

5 Setting Up

5.1 Introduction

The basic equation for volume measurement using the flow sensor is:

$$Q = A F_i F_p V$$

Where: Q = flow rate,
 F_i = insertion factor
 F_p = profile factor
 V = velocity
 A = area

The profile factor and insertion factor must be determined as detailed in Sections 5.2 and 5.3 as applicable. The pipe diameter must be accurately determined, see Appendix B, page 28 page for use of gauge.

Note. Due to software configuration, all calculations are in metric units. Therefore if using an imperial pipe, the diameter MUST be converted into millimeters (1 in. = 25.4 mm, for example, a 36 in. pipe = 914 mm).

5.2 Centre Line Method

1. Determine the internal diameter D of the pipe, in millimeters, by the most accurate method available.
2. Determine the profile factor F_p from Fig. 5.1.
3. Calculate the insertion factor

$$F_i = \frac{1}{1 - (38 / (\pi D))}$$

Example – for a pipe of internal diameter 593 mm (23.35 in.):

F_p = 0.861 (derived from Fig. 5.1)

$$F_i = \frac{1}{1 - (38 / (\pi 593))}$$

F_i = 1.021

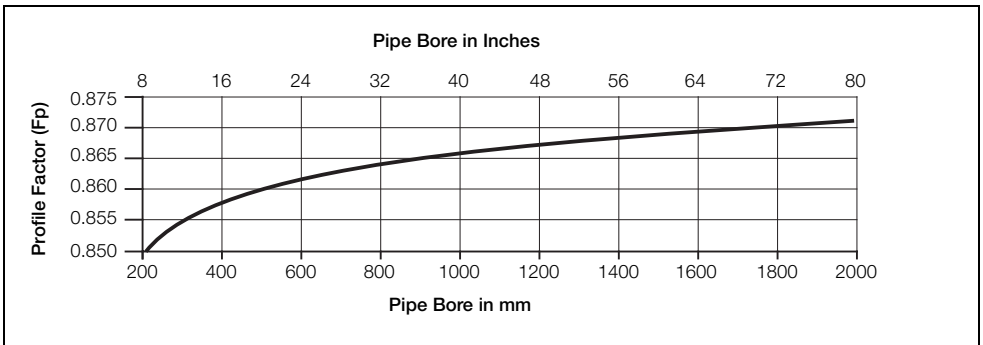

Fig. 5.1 Profile Factor v Flow Velocity for Pipe Sizes 200 to 2000 mm (8 to 80 in.)

5.3 Mean Axial Velocity Method ($1/8$ Diameter)

1. Determine the internal diameter D of the pipe, in millimeters, by the most accurate method available.
2. A profile factor F_p of 1 must be used.
3. Calculate the insertion factor

$$F_i = \left[1 + \frac{12.09}{D} + \frac{1.3042}{\sqrt{D}} \right]$$

Example – for a pipe of internal diameter 593 mm (23.35 in.):

$$F_p = 1$$

$$F_i = \left[1 + \frac{12.09}{593} + \frac{1.3042}{\sqrt{593}} \right]$$

$$F_i = 1.074$$

5.4 Partial Velocity Traverse

Refer to Appendix A.2.1, page 26 for the procedure.

5.5 Transmitter Setup

The transmitter can be set up to display point velocity, mean velocity or flow rate, as required. For full programming details refer to the relevant user guide:

WaterMaster FET100:

- User Guide – OI/FET100-EN
- Programming Guide – IM/WMP
- User Guide Supplement, PROFIBUS RS485 Physical Layer – IM/WMPBS-EN
- User Guide Supplement, PROFIBUS FEX100-DP Parameter Tables – IM/WMPBST-EN

AquaMaster 3 FET200:

- User Guide – OI/FET200-EN
- Programming Guide – COI/FET2XX-EN
- MODBUS Tables Supplement – COI/FET2XX/MOD/TBL-EN

Menu entries must be made for:

- Profile Factor F_p
- Insertion Factor F_c
- Flow sensor pipe bore (mm)

6 Specification

FEA100/FEA200 Flow Sensor

Maximum insertion length

300mm (12 in.)

500mm (20 in.)

700mm (25 in.)

1000mm (40 in.)

Pipe sizes

200 to 8000 mm (8 to 320 in.) nominal bore

Protection

IP68/NEMA 6P (Indefinite submersion down to 10 m [30 ft.])

Weight

<3.5kg (7.7 lb)

Accuracy**Velocity** $\pm 2\%$ of Rate or $\pm 2\text{mm/s}$ ($\pm 0.08\text{ in./s}$) whichever is the greater**Volume**

Refer to ISO 7145-1982 (BS 1042 section 2.2) for details

Flow conditionFully developed profile in accordance with
ISO 7145-1982 (BS1042 section 2.2.)**Pressure limitations**

20 bar (295 psi)

Max. Pressure

20 bar (295 PSI)

Pressure equipment Directive 97/23/EC

This product is applicable in networks for the supply, distribution and discharge of water and associated equipment and is therefore exempt

Conductivity>50 $\mu\text{S/cm}$ **Connections**

1 in. BSP

1 in. NPT

1.5 in. BSP

Maximum Flow

The maximum velocity depends upon the actual insertion length. Typical insertion lengths are 0.125 and 0.5 x pipe diameter.

The graph is a guide* to the maximum allowable velocity for different insertion lengths.

*The graph is intended as a guide only. Factors that influence the maximum insertion length into the pipe include: flow sensor mounting components, for example, standoffs, bushes and valves; other influences include pipeline vibration, fluid vibration and pump noise.

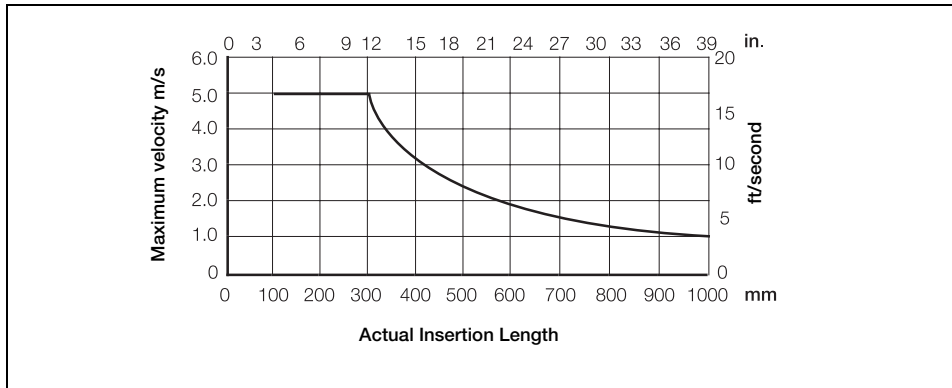

Wetted Materials

Body

Stainless steel

Flow Sensor

Suitable for potable water (WRAS listed)

Electrodes – stainless steel 316L

Seals

Suitable for potable water (WRAS listed)

Temperature Ranges

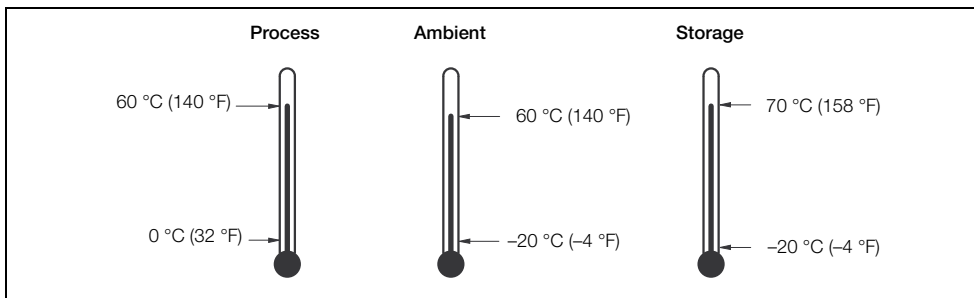

Limits of Upstream Disturbance

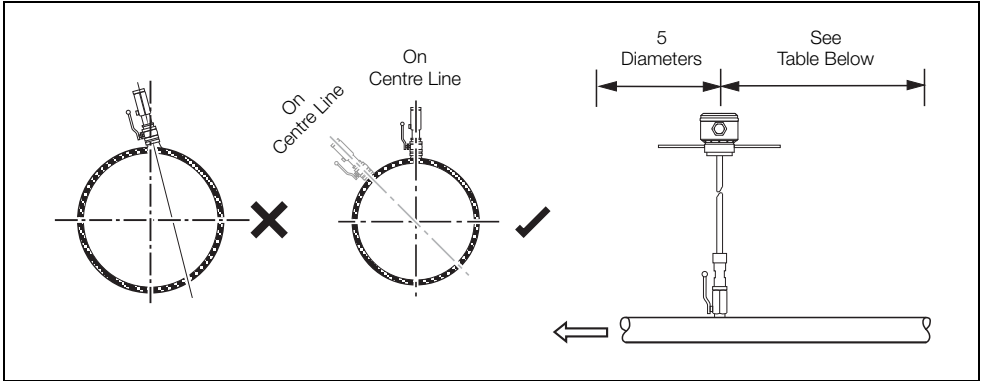

Type of Disturbance Upstream from the Measuring Cross-Section	Minimum Upstream Straight Length*	
	For a measurement at the point of mean axial velocity	For a measurement on the axis of the conduit
90° Elbow or a T-bend	50	25
Several 90° Coplanar Bends	50	25
Several 90° Non-coplanar Bends	80	50
Total Angle Convergent 18 to 36°	30	10
Total Angle Divergent 14 to 28°	55	25
Fully Opened Butterfly Valve	45	25
Fully Opened Plug Valve	30	15

*Expressed in multiples of the diameter of the conduit.

Downstream from the measurement cross-section, the straight length must be at least equal to five duct diameters whatever the type of disturbance.

Note. This Table is an extract from ISO7145 (BS 1042): Section 2.2: 1982 and is reproduced with the permission of BSI. Complete copies of the standard can be obtained by post from BSI Publications, Linford Wood, Milton Keynes, MK14 6LE.

Appendix A

A.1 – Velocity Profiles Background

Fig. A.1 is a vector diagram showing a fully developed turbulent profile of the flow within a pipe. Such diagrams illustrate the distribution of flow within a pipe. Known as the Flow Profile, it is highest in the centre falling to zero at either side on the pipe wall. If there is sufficient upstream straight pipe, it can be assumed that there is a profile of this form. In this example, the pipe is 600 mm in diameter, the velocity at the centre line is 2 m/s and the flow is 487 l/s.

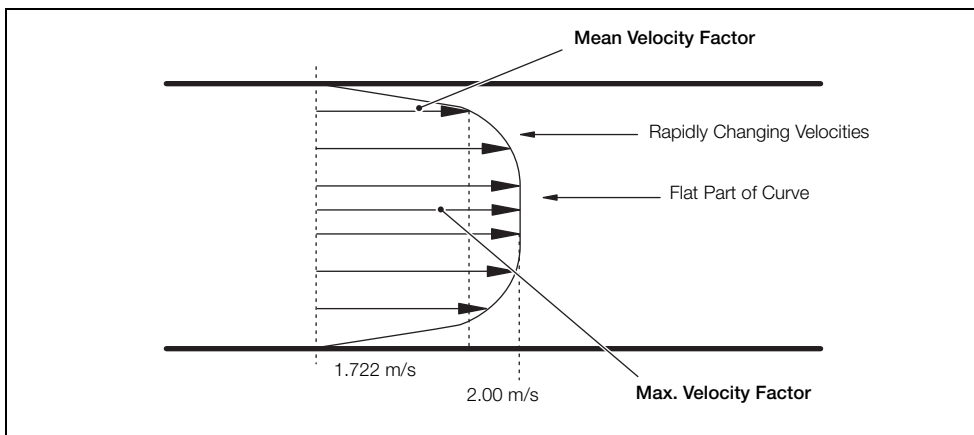

Fig. A.1 Turbulent Flow Profile

As the volume flow is known, the mean velocity in the pipe can be calculated – note that at 1.722 m/sec, it is actually lower than the velocity measured on the centre line. Careful investigation of this profile or vector diagram reveals that the mean velocity of 1.722 m/sec occurs at a point 72.5 mm or $\frac{1}{8}$ of the pipe's diameter in from the edge of the pipe. This point is referred to as the Point of Mean Velocity (for a fully developed turbulent flow profile only). This is true (provided the profile is turbulent and fully developed) for all pipes of all sizes and at all flow rates, and is recognized in British Standard 1042 (see Section 3.3.1, page 8). Therefore, the best position to measure velocity is at the Point of Mean Velocity, i.e. $\frac{1}{8}$ of the diameter in from the edge of the pipe. By placing the probe at this point a straightforward calculation of volume flow can be performed – but there is more to be considered ...

The Point of Mean Velocity is on the knee of the curve (the velocity at this point is changing rapidly with distance) so it is necessary to position the probe extremely accurately in order to measure the correct velocity. If the probe is inserted accurately to 72.5 mm, it is therefore measuring the mean velocity of 1.722 m/s which, when multiplied by the area, gives a volume flow of 487 l/s. If the probe is inserted to 74 mm instead of 72.5, the velocity measurement is 1.85 m/s instead of the expected 1.722. Multiplying this figure by the area results in a volume flow of 523 l/sec – an error of 7.4 %.

On-site it can be very difficult to locate a probe exactly, so this sort of error is quite common. With devices other than AquaProbe, working under any degree of pressure in the line, inserting a probe to within 10 mm of its intended location is often accepted. Using the calculation above, this produces an error of approximately 15 %. This can be reduced significantly by using the following method.

Referring to Fig. A.1, in the middle of the pipe, near the centre line, the profile is relatively flat, i.e. the flow velocity does not change very much with distance into the pipe. Therefore, if the velocity is measured on the centre line, measurement errors due to positional errors (i.e. not locating the probe where required) are very small; hence most users will try to use the centre line measuring position. However, as explained previously, this process gives us the wrong answer, Fortunately there is a mathematical relationship between the velocity at the centre line and the mean velocity within the pipe – the **Profile Factor (Fp)**. The value of Fp can be calculated by an equation (below) or obtained from a graph – see Fig. A.2.

Fp is calculated as follows:

$$F_p = 1 - \left[\frac{(r - Y_b)}{r} \right]^{\frac{1}{n}}$$

Where:

$$Y_b = r \left[\frac{2n^2}{(n+1)(2n+1)} \right]^{\frac{1}{n}}$$

And:

$$n = 1.66 \log(R_e)$$

And:

$$R_e = \frac{D \rho v}{\mu}$$

D = Pipe Diameter

ρ = Fluid Density

v = Average Fluid Velocity

μ = Fluid Viscosity

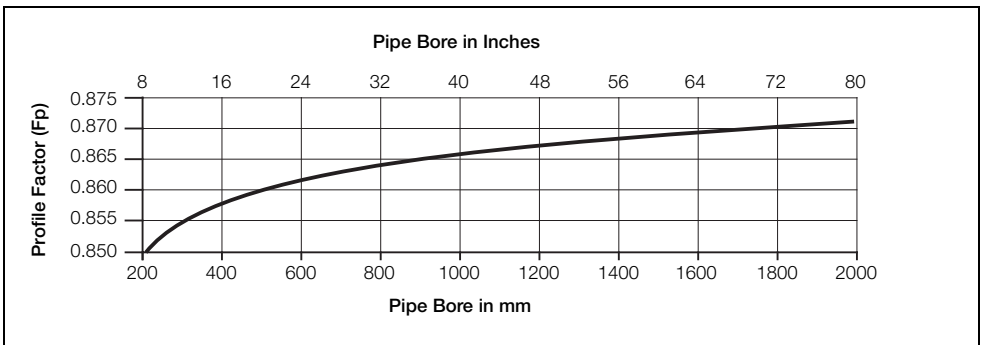

Fig. A.2 Profile Factor v Flow Velocity for Pipe Sizes 200 to 2000 mm (8 to 80 in.)

When the probe insertion position is determined, the effect of putting the probe into the pipe (see Section 3.3.2, page 8) must be calculated.

The blockage or insertion effect is termed the **Insertion Factor (Fi)**. This is a mathematical relationship and is calculated from the formula:

$$F_i = \frac{1}{1 - (38/(\pi D))}$$

A.2 Testing the Flow Profile for Symmetry

If there is any doubt as to the symmetry of the flow profile (see Section 3.3, page 7), a Partial Velocity Traverse must be carried out. This procedure involves comparing the value of velocity at two points at equal distances from the centre line.

It is normal to compare the flow velocities at insertion depths of $1/8$ and $7/8$ of the pipe diameter as these points are always on the 'knee' of the profile.

A.2.1 Partial Velocity Traverse

Determine the internal diameter D of the pipe, in millimeters, by the most accurate method available. If the flow sensor insertion length is greater than the internal diameter of the pipe, proceed with the Single Entry Point Method detailed in Section A.2.2. If the flow sensor's insertion length is less than the internal diameter of the pipe, proceed with the Dual Entry Point Method detailed in Section A.2.3, page 27.

A.2.2 Single Entry Point Method

1. Insert the flow sensor to a depth of $1/8$ the pipe diameter – see Fig. 3.11, page 15.

Note. Due to software configuration, all calculations are in metric units. Therefore if using an imperial pipe, the diameter **MUST** be converted into millimeters (1 in. = 25.4 mm, for example, a 36 in. pipe = 914 mm).

2. Calculate the insertion factor

$$F_i = \left[1 + \frac{12.09}{D} + \frac{1.3042}{\sqrt{D}} \right]$$

3. Refer to the relevant user guide* and enter an Insertion Factor of value equal to F_i .
4. Record the flow velocity reading.
5. Insert the flow sensor to a depth of $7/8$ the pipe diameter.

6. Calculate the insertion factor.

$$F_i = \left[1 + \frac{12.09}{D} + \frac{1.3042}{\sqrt{D}} \right]$$

7. Refer to the relevant user guide* and enter an Insertion Factor of value equal to F_i .
8. Record the flow velocity reading.
9. Calculate the ratio of the two values recorded.
 - if the calculated ratio is between 0.95 and 1.05, the flow profile is acceptable and the procedure detailed in Section 5.2, Page 19 can be used,
 - or
 - if the calculated ratio is **not** between 0.95 and 1.05, re-site the flow sensor for optimum accuracy.

*WaterMaster FET100 (OI/FET100-EN) or AquaMaster 3 FET200 (OI/FET200-EN)

A.2.3 Dual Entry Point Method

Refer to Section 3.6, page 12 and fit a second mounting boss directly opposite the one already fitted.

Note. Due to software configuration, all calculations are in metric units. Therefore if using an imperial pipe, the diameter **MUST** be converted into millimeters (1 in = 25.4 mm, for example, a 36 in. pipe = 914 mm).

1. Insert the flow sensor to a depth of $\frac{1}{8}$ the pipe diameter through the original mounting boss.
2. Calculate the insertion factor.

$$F_i = \left[1 + \frac{12.09}{D} + \frac{1.3042}{\sqrt{D}} \right]$$

3. Refer to the relevant user guide* and enter a Insertion Factor of value equal to F_i .
4. Record the flow velocity reading.
5. Insert the flow sensor to a depth of $\frac{1}{8}$ the pipe diameter through the second mounting boss.
6. Record the flow velocity reading.
7. Calculate the ratio of the two values recorded
 - if the calculated ratio is between 0.95 and 1.05, the flow profile is acceptable and the procedure detailed in Section 5.2, page 19 can be used
 - or
 - if the calculated ratio is **not** between 0.95 and 1.05, re-site the flow sensor for optimum accuracy

*WaterMaster FET1 (OI/FET100-EN) or AquaMaster 3 FET2 (OI/FET200-EN)

A.3 Full Velocity Profile

For installations with very poor and asymmetric velocity profiles (for example as rejected in Section A.2.2, page 26) a full velocity profile provides an improved accuracy of reading. To facilitate this ABB have developed *ScrewDriver* software for the PC that calculates F_i and F_p for any measured velocity profile – see IM/SDR section 'ABB Flow Profiling'.

Appendix B – Measuring the Internal Diameter

When a standard full-bore electromagnetic flowmeter is manufactured, it is usually supplied in a nominal bore size of a round figure anywhere between 15 and 2000 mm (for example 600 mm, 700 mm). Rarely are flowmeters precisely this nominal size, but it is not important as the wet flow calibration (performed on ABB's UKAS-approved and traceable flow rigs in the UK) compensates for small deviations in size. In the case of a probe, clearly it can't be tested in the pipe in which it is to be finally installed. It is therefore not possible to take account of the difference between the nominal or expected internal diameter of the pipe and its actual value.

Since the relationship between the point velocity measurement and the flow depends on the area of the cross section of the pipe ($\pi \times$ the radius squared), an error in the value of the internal diameter of the pipe causes a much greater error in the volume flow measurement due to the 'square effect'. Therefore it is essential, whenever possible, to measure the internal diameter accurately to eliminate this extra source of errors. ABB supply an internal pipe-measuring probe (Pipe-bore Gauging Tool) for this purpose. The tool is used as follows:

1. Fit the tool into the back of the valve, so that the red line on top of the fitting and the handle of the tool is in line longitudinally with the centre line of the pipe.
2. Open the valve and push the tool in gently until it touches the other side of the pipe.
3. Back off the tool a small amount and rotate the handle through 180° so it is again in line with the longitudinal axis of the pipe.
4. Push the tool down again carefully until it touches the wall of the pipe. Now, slide the small collar on the tool down to touch the top of the fitting.
5. Pull the tool back carefully until it touches the top of the pipe. During this withdrawal, take care not to touch the sliding collar. This distance between the top knife-edge of the sliding collar and the top of the fitting is the internal diameter of the pipe. Measure this distance using a good quality tape rule.
6. Once the diameter has been measured and recorded, push the measuring tool back into the pipe a little then turn it through 180° so that the handle is once more in line with the longitudinal axis of the pipe and in the same direction as the red line on the top fitting.
7. Retract the probe fully into its fitting and close the valve fully.

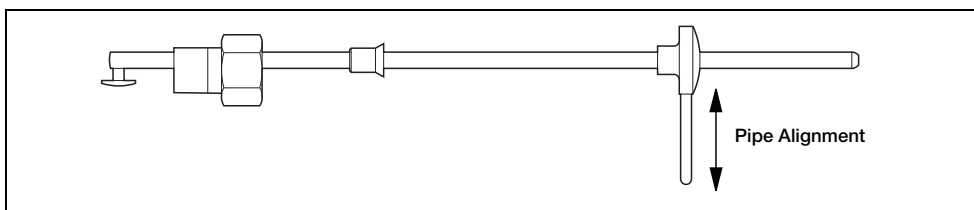

Fig. B.1 Pipe-bore Gauging Rod

Products and customer support

Automation Systems

For the following industries:

- Chemical & Pharmaceutical
- Food & Beverage
- Manufacturing
- Metals and Minerals
- Oil, Gas & Petrochemical
- Pulp and Paper

Drives and Motors

- AC and 6 Drives, AC and DC Machines, AC Motors to 1kV
- Drive Systems
- Force Measurement
- Servo Drives

Controllers & Recorders

- Single and Multi-loop Controllers
- Circular Chart and Strip Chart Recorders
- Paperless Recorders
- Process Indicators

Flexible Automation

- Industrial Robots and Robot Systems

Flow Measurement

- Electromagnetic Flowmeters
- Mass Flowmeters
- Turbine Flowmeters
- Wedge Flow Elements

Marine Systems & Turbochargers

- Electrical Systems
- Marine Equipment
- Offshore Retrofit and Refurbishment

Process Analytics

- Process Gas Analysis
- Systems Integration

Transmitters

- Pressure
- Temperature
- Level
- Interface Modules

Valves, Actuators and Positioners

- Control Valves
- Actuators
- Positioners

Water, Gas & Industrial Analytics Instrumentation

- pH, Conductivity and Dissolved Oxygen Transmitters and Sensors
- Ammonia, Nitrate, Phosphate, Silica, Sodium, Chloride, Fluoride, Dissolved Oxygen and Hydrazine Analyzers
- Zirconia Oxygen Analyzers, Katharometers, Hydrogen Purity and Purge-gas Monitors, Thermal Conductivity

Customer support

We provide a comprehensive after sales service via a Worldwide Service Organization. Contact one of the following offices for details on your nearest Service and Repair Centre.

UK

ABB Limited
Tel: +44 (0)1453 826661
Fax: +44 (0)1453 829671

USA

ABB Inc.
Tel: +1 215 674 6000
Fax: +1 215 674 7183

Client Warranty

Prior to installation, the equipment referred to in this manual must be stored in a clean, dry environment, in accordance with the Company's published specification.

Periodic checks must be made on the equipment's condition. In the event of a failure under warranty, the following documentation must be provided as substantiation:

- A listing evidencing process operation and alarm logs at time of failure.
- Copies of all storage, installation, operating and maintenance records relating to the alleged faulty unit.

ABB Limited

Process Automation

Oldends Lane
Stonehouse
Gloucestershire GL10 3TA
UK

Tel: +44 1453 826 661

Fax: +44 1453 829 671

ABB Inc.

Process Automation

125 E. County Line Road
Warminster
PA 18974
USA

Tel: +1 215 674 6000

Fax: +1 215 674 7183

www.abb.com

Note

We reserve the right to make technical changes or modify the contents of this document without prior notice. With regard to purchase orders, the agreed particulars shall prevail. ABB does not accept any responsibility whatsoever for potential errors or possible lack of information in this document.

We reserve all rights in this document and in the subject matter and illustrations contained therein. Any reproduction, disclosure to third parties or utilization of its contents – in whole or in parts – is forbidden without prior written consent of ABB.

Copyright© 2011 ABB

All rights reserved

3KXF224001R4201

MODDBUS is a registered trademark of the Modbus-IDA organization.

PROFIBUS is a registered trademark of PROFIBUS organization.

01/FEA100/200-EN 09.2011